

INSTALLATION INSTRUCTIONS



PRO SERIES REAR BUMPER

APPLICATION:
2023-2024 F-250/350

PART NUMBER:
58-421275

| CONTENT | | | |
|---------|----------|--|---------------|
| ITEM | QUANTITY | DESCRIPTION | TOOLS NEEDED |
| 1 | 1 | REAR BUMPER | 10MM SOCKET |
| 2 | 1 | DRIVER MONTING BRACKET | 10MM WRENCH |
| 3 | 1 | PASSENGER MOUNTING BRACKET | 19MM SOCKET |
| 4 | 4 | SENSOR L-TAB | 19MM WRENCH |
| 5 | 4 | SENSOR HOLE PLUG | TRIM TOOL |
| 6 | 2 | SUPPORT BRACKET | RATCHET |
| 7 | 14 | M12 SPLIT LOCK WASHER (YELLOW ZINC) | TORQUE WRENCH |
| 8 | 28 | M12 FLAT WASHER (YELLOW ZINC) | |
| 9 | 14 | M12 HEX NUT (YELLOW ZINC) | |
| 10 | 4 | M6 FLAT WASHER (YELLOW ZINC) | |
| 11 | 4 | M6 HEX NUT (YELLOW ZINC) | |
| 12 | 4 | M6 SPLIT LOCK WASHR (YELLOW ZINC) | |
| 13 | 14 | M12 SERRATED FLANGE BOLT (BLACK ZINC) | |
| 14 | 4 | M6 ROUND HEAD SQUARE NECK BOLT (BLACK ZINC) | |
| 15 | 6 | M6 HEX SOCKET BUTTON HEAD SCREW (BLACK ZINC) | |
| 16 | 6 | M6 FLANGE NUT (BLACK ZINC) | |
| 17 | 6 | M6 FLAT WASHER (BLACK ZINC) | |

ANTI-SEIZE LUBRICANT MUST BE USED ON ALL STAINLESS STEEL FASTENERS TO PREVENT THREAD DAMAGE AND GALLING

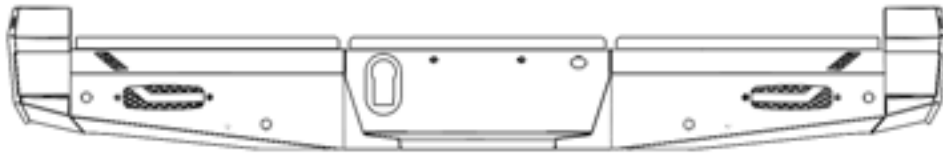

ITEM 1



ITEM 4



ITEM 5



ITEM 6



ITEM 2

PROCEDURE

1. Remove contents from box, verify if all parts listed are present and free from damage.
Carefully read and understand all instructions before attempting installation.
Failure to identify damage before installation could lead to a rejection of any claim.

2. Remove all electrical connections.
3. Remove the two lower bolts at the bottom of the bumper. See **Figure 1**
4. Remove the six bolts holding the rear bumper on.
5. Remove the rear bumper.

Figure 1

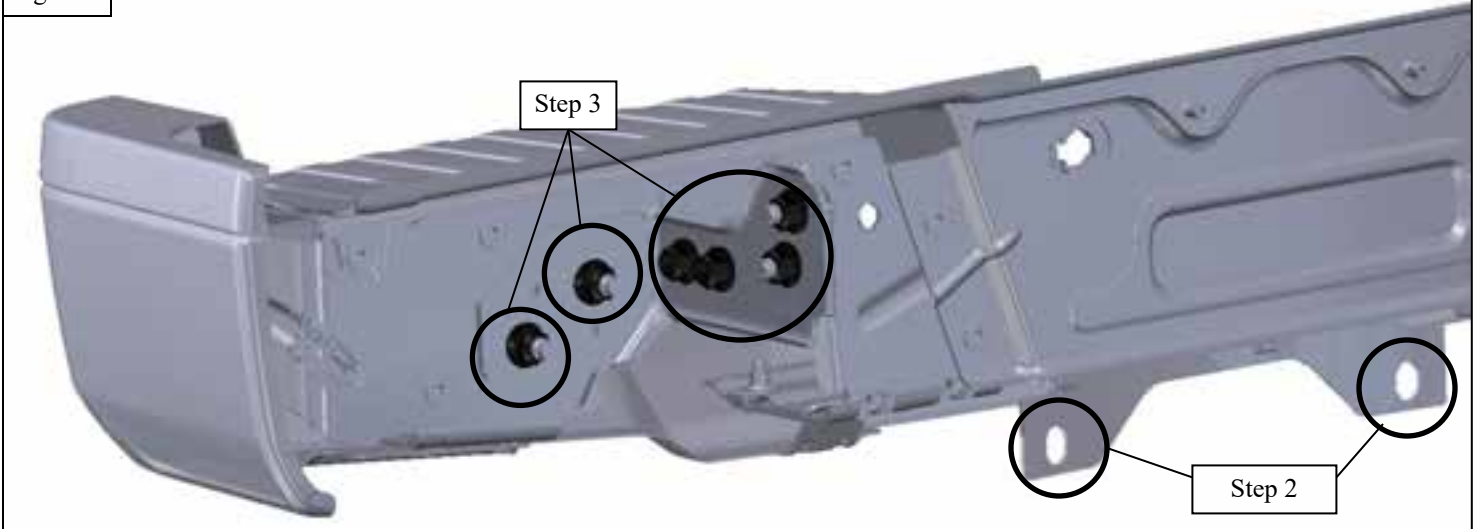

6. Mount the support brackets (Item 6) on the mounting brackets as seen in **Figure 2** using the OE hardware.

Figure 2



5. **If sensors are equipped:** Install parking sensors by inserting into the holes on bumper and pressing with sensor L-tabs against bumper plate. Fasten L-tabs with the supplied M6 hardware (10-13) . **See Figure 2-5.** Use supplied double sided tape between sensor and L-Tab to keep the sensor from rotating.
If sensors are not equipped: Place the supplied plugs in the sensor holes.
6. Use zip ties to secure sensor in place.
Note: Be sure to maintain the orientation of the sensor so that it remains consistent with its original orientation.
7. Tighten M6 hardware to 5-7 ft-lbs.

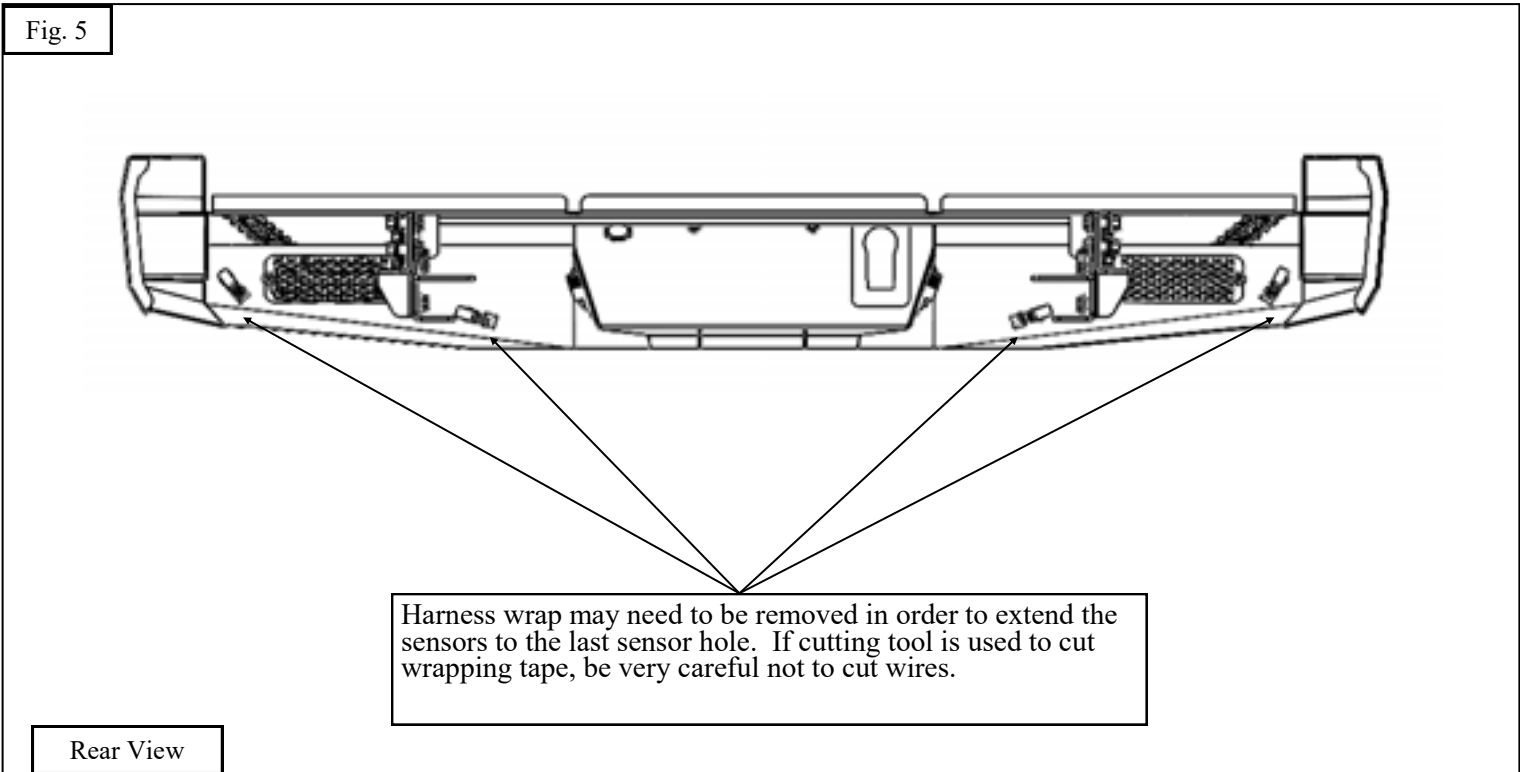
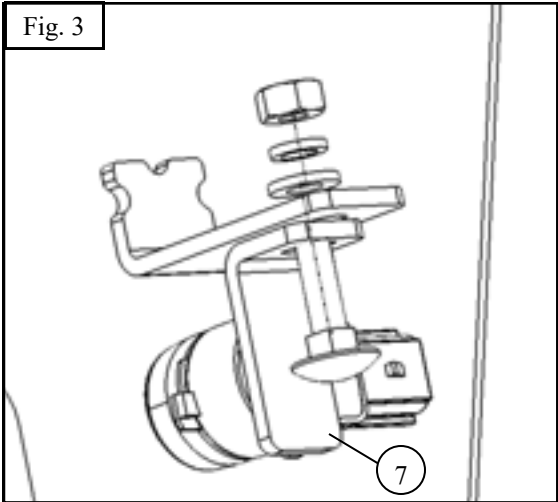

8. Using the supplied M12 hardware, loosely assemble the mounting brackets to the factory tow hitch. See Figure 6.
9. Loosely assemble the bumper on to the mounting brackets using the supplied M12 hardware.

Fig. 6

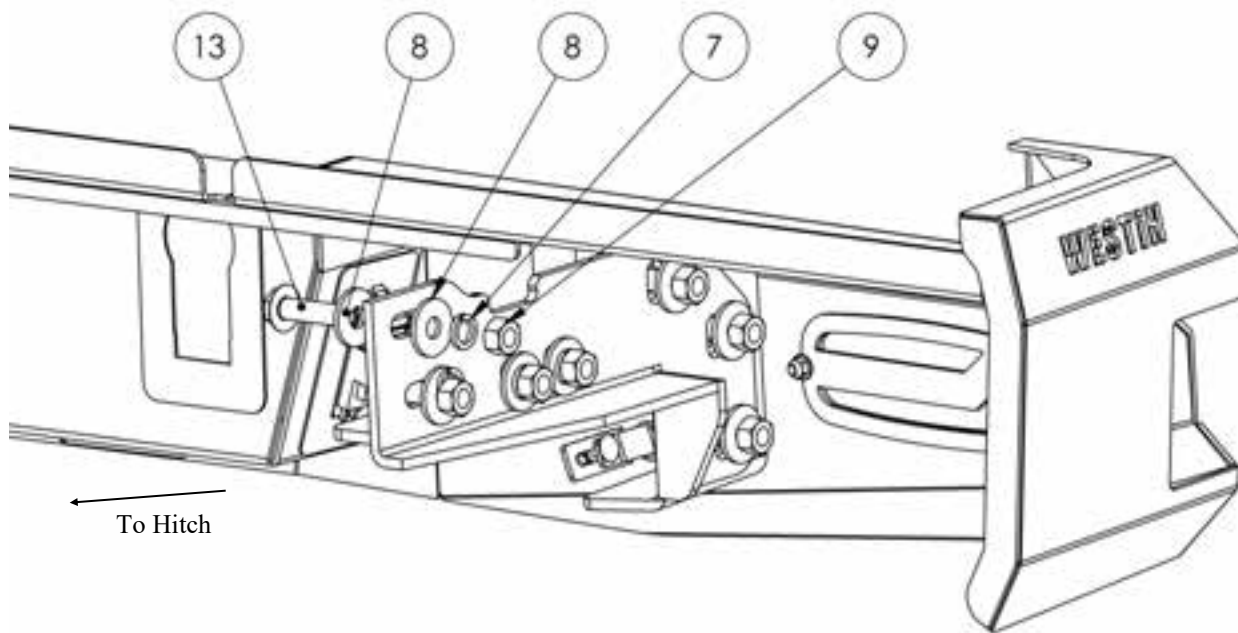

11. Install the trailer plug in to the trailer plug slot in the bumper.
12. Install the license plate at this time.

WARNING .

After you have mounted bumper on main brackets. CAREFULLY open tailgate. While tailgate is open, adjust the height of the bumper so that it has about 3/8" of clearance with respect to the tailgate. Then, tighten all M12 hardware to 50-55 ft-lbs.



Westin Automotive Products, Inc.
320 W. Covina Blvd
San Dimas, Ca. 91773

Thank you for choosing Westin products
for additional installation assistance please call
Customer Service (800) 793-7846
www.westinautomotive.com

License plate lights installation.

1. Disconnect the battery from your vehicle.
 2. Locate the license plate lights (pre-installed) in the bumper. Pop out the lights by squeezing the clips in on the backside. **See Figure 7**
 3. Locate the factory wiring for the license plate lights. Strip back the wiring on the factory harness and supplied light. Using connectors, crimp the red wire on the positive factory wire and the black wire to the factory ground wire. **See Figure 8**
- Note: Only the portion shown on **Figure 9** will be needed from the connector.

Figure 7

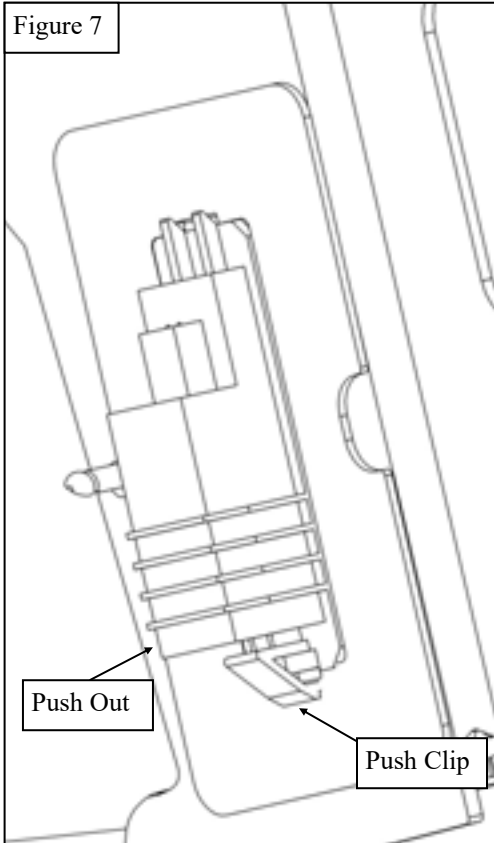

Figure 8



Figure 9



4. Push the light back in until it clips into place. Repeat on the opposite side. **See Figure 10**

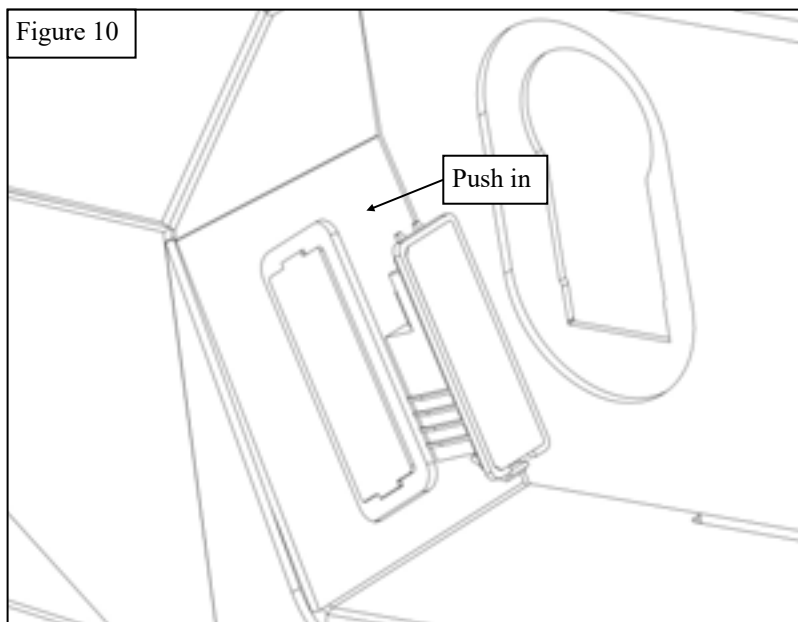

5. If you are installing the optional reverse lights, remove the mesh covers and install the optional lights with the M6 hardware. **See Figure 11**
6. Locate the factory wiring for the reverse lights. Strip back the wiring on the factory harness and supplied light. Using connectors, crimp the red wire on the positive factory wire and the black wire to the factory ground wire.
7. Reconnect your battery.

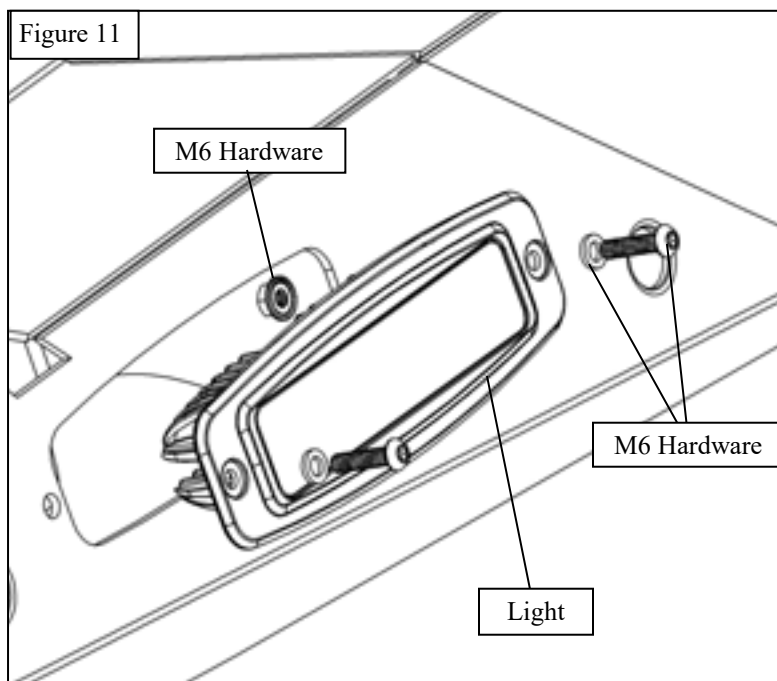

INSTALLATION COMPLETE



CARE INSTRUCTIONS

- REGULAR WAXING IS RECOMMENDED. DO NOT USE ANY TYPE OF POLISH OR WAX THAT MAY CONTAIN ABRASIVES.
- STAINLESS STEEL PRODUCTS CAN BE CLEANED WITH MILD SOAP AND WATER. STAINLESS STEEL POLISH SHOULD BE USED TO POLISH SMALL SCRATCHES.
- GLOSS BLACK FINISHES SHOULD BE CLEANED WITH MILD SOAP AND WATER.

WESTIN

Westin Automotive Products, Inc.
320 W. Covina Blvd
San Dimas, Ca. 91773

Thank you for choosing Westin products
for additional installation assistance please call
Customer Service (800) 793-7846
www.westinautomotive.com



WARNING



Failure to follow these instructions could lead to death, personal injury, and / or property damage.

Failure to follow these instructions could lead to death, personal injury, and / or property damage.

FASTENERS:

All Westin supplied fasteners must be utilized and installed in accordance with the installation instructions and apply torque to the specifications as defined. **DOUBLE CHECK ALL FASTENERS BEFORE INITIAL USE, AND PERIODICALLY IN THE FUTURE TO ENSURE PROPER FUNCTION AND SAFETY.**

DRILLING:

Most Westin products do not require drilling for installation. If drilling is defined as required, use caution when drilling a vehicle. **FAILURE TO REVIEW AN AREA TO BE DRILLED MAY RESULT IN PERSONAL INJURY AND/OR INJURY TO OTHERS AS WELL AS VEHICLE DAMAGE.**

EYE PROTECTION:

ALWAYS WEAR SAFETY GLASSES OR GOGGLES DURING THE INSTALLATION PROCESS TO AVOID PERSONAL INJURY.

MAXIMUM TOWING/CARRYING CAPACITY: (if applicable)

The Westin Receiver Hitches will have a visible tow rating label affixed directly on the product. User should never exceed the vehicle manufacturers maximum tow and weight rating regardless of the capacity of the hitch. **FAILURE TO FOLLOW THESE GUIDELINES WILL VOID THE WESTIN WARRANTY AND MAY RESULT IN PERSONAL INJURY AND/OR INJURY TO OTHERS AS WELL AS VEHICLE DAMAGE.**

FOR CALIFORNIA RESIDENTS ONLY-PROP 65 WARNING:

Some products may contain chemicals such as DEHP, which can cause cancer, birth defects or other reproductive harm. For more info go to www.p65warnings.ca.gov



Westin Automotive Products, Inc.
320 W. Covina Blvd
San Dimas, Ca. 91773