

INSTALLATION INSTRUCTIONS



PIT BAR ELITE-XD

APPLICATION:

2021-2025 Ford F-150 / F-150 Police Responder / F-150 XL SSV

PART NUMBER: 36-54085PB

CONTENT			
ITEM	QUANTITY	DESCRIPTION	TOOLS NEEDED
1	2	PIT BAR ASSEMBLY (1 DRIVER, 1 PASSENGER)	16MM SOCKET
2	1	DRIVER SIDE MOUNTING BRACKET	16MM WRENCH
3	1	PASSENGER SIDE MOUNTING BRACKET	18MM SOCKET
4	1	DRIVER SIDE CUTTING TEMPLATE	18MM WRENCH
5	1	PASSENGER SIDE CUTTING TEMPLATE	19MM SOCKET
6	2	SPACER	19MM WRENCH
7	6	SHORT M10 HEX SOCKET BUTTON HEAD SCREW	RATCHET
8	2	LONG M10 HEX SOCKET BUTTON HEAD SCREW	TORQUE WRENCH
9	8	M10 BELLVILLE WASHER	ALLEN WRENCH
10	8	M10 SERRATED FLANGE NUT	
11	2	M12 HEX SOCKET BUTTON HEAD SCREW	
12	2	M12 BELLVILLE WASHER	
13	2	M12 SERRATED FLANGE HEX HEAD SCREW	

ANTI-SEIZE LUBRICANT MUST BE USED ON ALL STAINLESS STEEL FASTENERS TO PREVENT THREAD DAMAGE AND GALLING

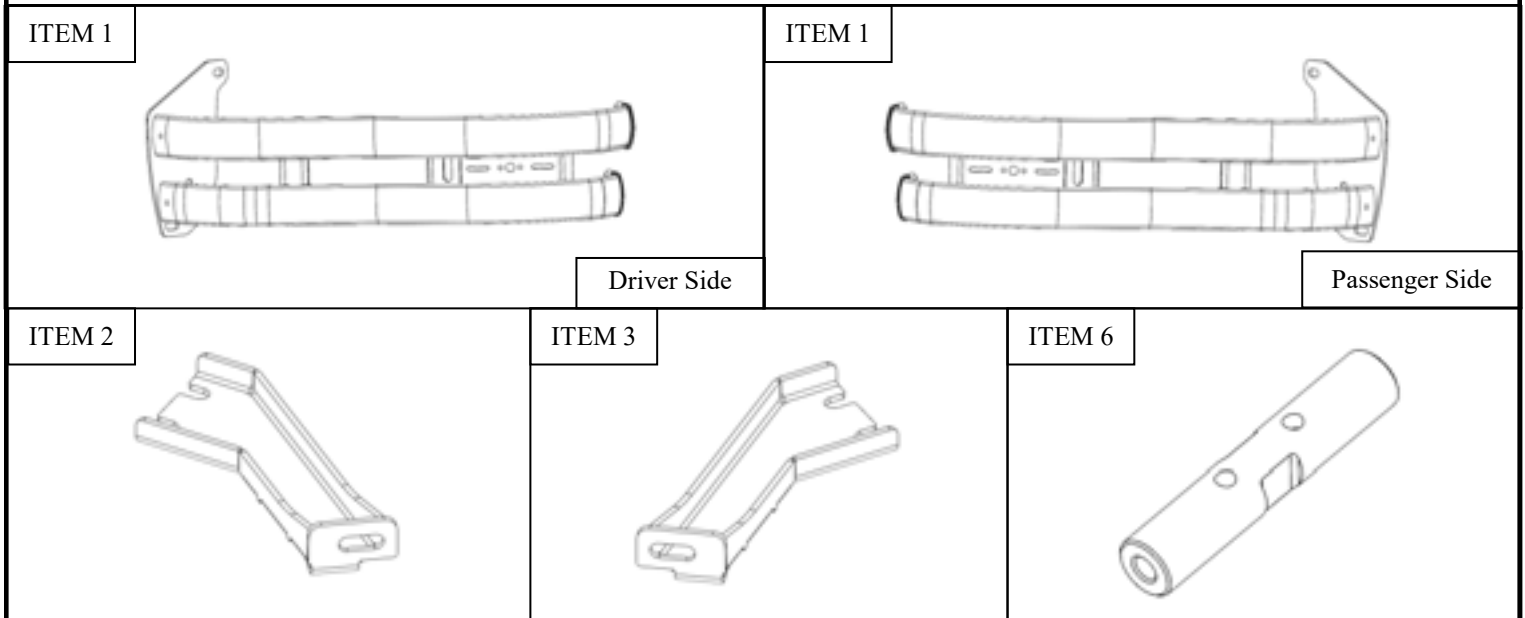

PROCEDURE

1. Remove contents from box, verify if all parts listed are present and free from damage.
Carefully read and understand all instructions before attempting installation.
Failure to identify damage before installation could lead to a rejection of any claim.
2. Remove the OEM front bumper by removing the inner 3 factory nuts on each side securing the bumper. Disconnect any wiring connectors pertaining to the front bumper and remove the bumper carefully. See **Figures 1** for reference.

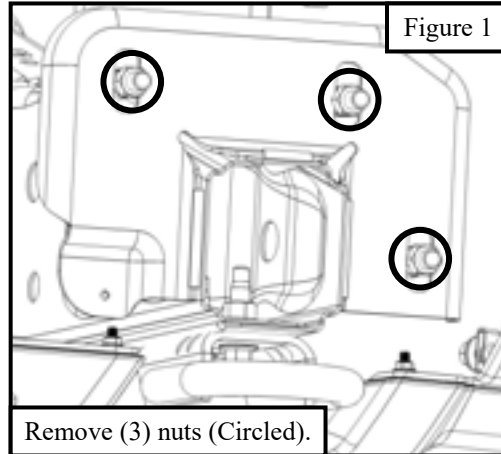

3. Starting on the frame just behind the bumper, loosen the two factory bolts at the locations shown in **Figure 2 & 3**. **Note:** *Loosen the bolts enough to allow room for mounting the Driver and Passenger Mounting Brackets in Step 2.*
4. Install the Mounting Brackets (Items 3 & 4) to the two factory bolts as shown in **Figure 2 & 3**. Tighten the bolts to secure the mounting brackets.
5. Reinstall the OEM front bumper at this time.

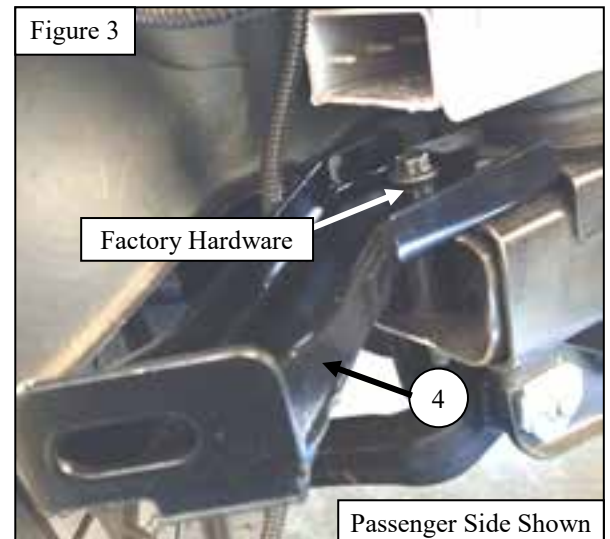
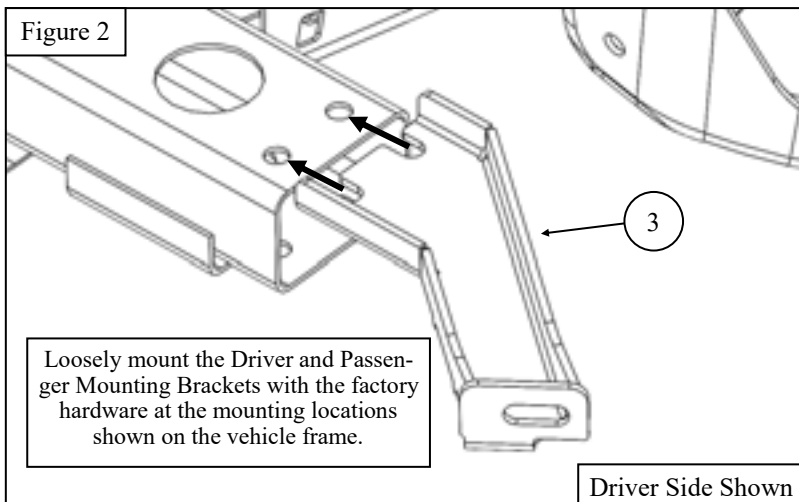

6. **NOTE: If you installing on a 2024 and later vehicle, please see insert page 4 for trimming instructions. Then continue to step 8 on this page.**
7. Use the supplied Template (Items 4 & 5) to determine where to drill a **1-1/2"** hole in the vehicle's bumper. Follow the instructions on the template, then mark and drill the **1-1/2"** hole needed to install the Pit Bar Assembly (Item 1). See **Figure 4** for template placement.
8. Install the Spacers (Item 6) to the Mounting Brackets using the provided M12 Serrated Screw (Item 13). See **Figure 6**.
9. Loosely install the Pit Bar Assembly (1) to your Push Bumper (P# 36-54085) using the supplied M10 Hardware. See **Figure 5**. **Note:** *Push Bumper (P# 36-54085) sold separately,*

Figure 4



Figure 4

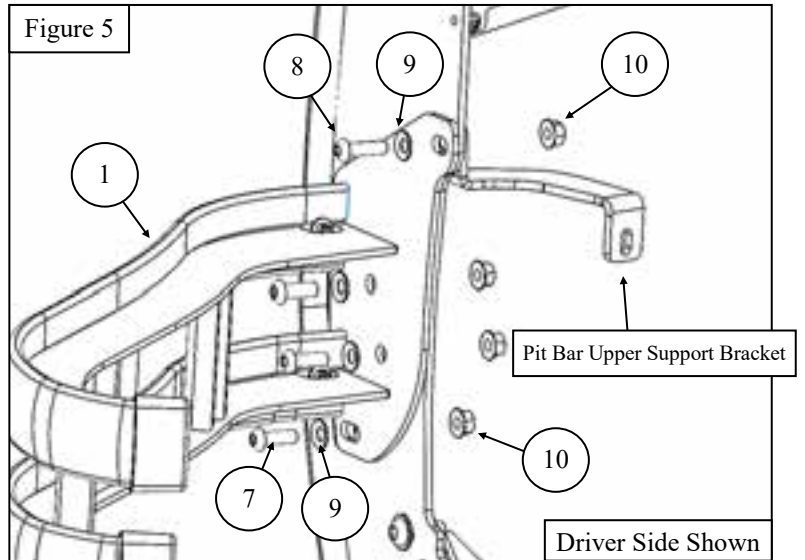
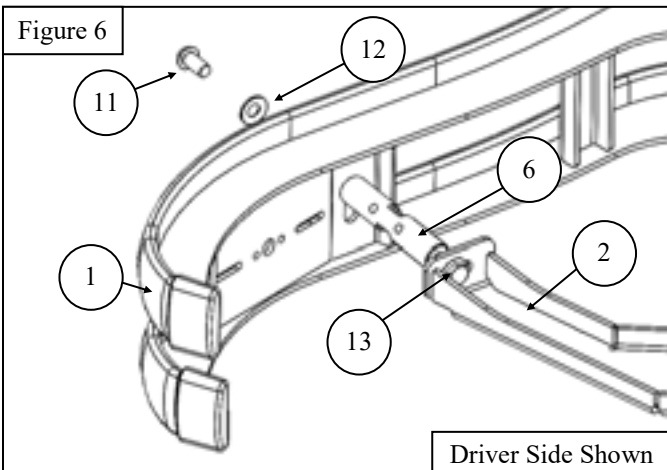

Figure 5

10. Use the supplied M12 Hardware and Spacer (Item 6) to secure the Pit Bar (1) to the Mounting Bracket on either side (Items 2 & 3). See **Figures 6 & 7** for reference.

Figure 6



Driver Side Shown

Figure 7

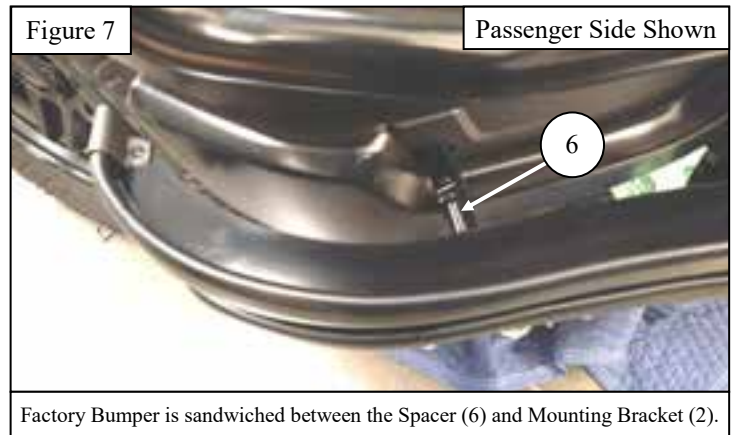

Passenger Side Shown

Factory Bumper is sandwiched between the Spacer (6) and Mounting Bracket (2).

**FOR VEHICLES 2024+ FORD F-150 / F-150 POLICE RESPONDER
USE THE DIMENSIONS BELOW TO TRIM HOLES TO INSTALL THE
ROUND BAR SPACER TO INSTALL THE PIT BAR.**

- Image below shows passenger side fog light opening.. Note: This product will not work if fog lights are installed.
- Use a 1/8" drill bit to drill a pilot hole at the location per dimensions below, then verify that the hole aligns with the slot in the bracket previously installed.
- Once verified. Use a 1 1/8" hole saw to trim the plastic..
- Proceed to step 8 at page 3.

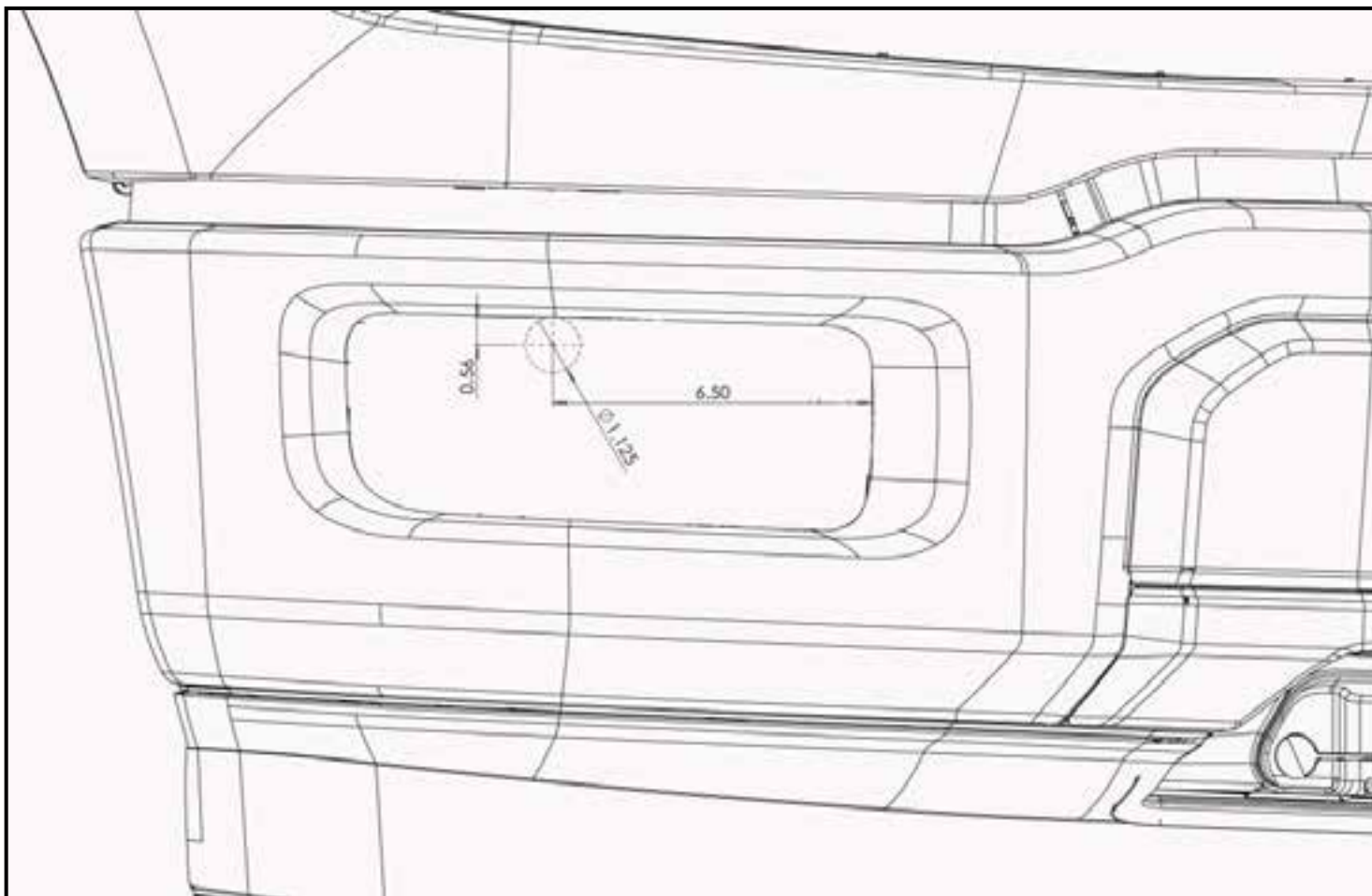

10. Align and adjust the Push Bumper and Pit Bar as needed then torque all hardware as follows: M10 Hardware to 35 ft-lb, M12 Hardware to 60 ft-lb.

11. *Optional Step: the provided holes on the Pit Bar can be used to mount an emergency light. See Figures 8 & 9 for reference.*

Figure 8



Figure 9



INSTALLATION COMPLETE



CARE INSTRUCTIONS

- REGULAR WAXING IS RECOMMENDED. DO NOT USE ANY TYPE OF POLISH OR WAX THAT MAY CONTAIN ABRASIVES.
- STAINLESS STEEL PRODUCTS CAN BE CLEANED WITH MILD SOAP AND WATER. STAINLESS STEEL POLISH SHOULD BE USED TO POLISH SMALL SCRATCHES.
- GLOSS BLACK FINISHES SHOULD BE CLEANED WITH MILD SOAP AND WATER.

WESTIN Westin Automotive Products, Inc.
320 W. Covina Blvd
San Dimas, Ca. 91773

Thank you for choosing Westin products
for additional installation assistance please call
Customer Service (800) 793-7846
www.westinautomotive.com



WARNING



Failure to follow these instructions could lead to death, personal injury, and / or property damage.

Failure to follow these instructions could lead to death, personal injury, and / or property damage.

FASTENERS:

All Westin supplied fasteners must be utilized and installed in accordance with the installation instructions and apply torque to the specifications as defined. **DOUBLE CHECK ALL FASTENERS BEFORE INITIAL USE, AND PERIODICALLY IN THE FUTURE TO ENSURE PROPER FUNCTION AND SAFETY.**

DRILLING:

Most Westin products do not require drilling for installation. If drilling is defined as required, use caution when drilling a vehicle. **FAILURE TO REVIEW AN AREA TO BE DRILLED MAY RESULT IN PERSONAL INJURY AND/OR INJURY TO OTHERS AS WELL AS VEHICLE DAMAGE.**

EYE PROTECTION:

ALWAYS WEAR SAFETY GLASSES OR GOGGLES DURING THE INSTALLATION PROCESS TO AVOID PERSONAL INJURY.

MAXIMUM TOWING/CARRYING CAPACITY: (if applicable)

The Westin Receiver Hitches will have a visible tow rating label affixed directly on the product. User should never exceed the vehicle manufacturers maximum tow and weight rating regardless of the capacity of the hitch. **FAILURE TO FOLLOW THESE GUIDELINES WILL VOID THE WESTIN WARRANTY AND MAY RESULT IN PERSONAL INJURY AND/OR INJURY TO OTHERS AS WELL AS VEHICLE DAMAGE.**

FOR CALIFORNIA RESIDENTS ONLY-PROP 65 WARNING:

Some products may contain chemicals such as DEHP, which can cause cancer, birth defects or other reproductive harm. For more info go to www.p65warnings.ca.gov



Westin Automotive Products, Inc.
320 W. Covina Blvd
San Dimas, Ca. 91773