

INSTALLATION INSTRUCTIONS



**PUSH BUMPER ELITE XD
APPLICATION:
SILVERADO PPV 2023-2024**





**PART NUMBER:
36-52135**

CONTENT			
ITEM	QUANTITY	DESCRIPTION	TOOLS NEEDED
1	1	PUSH BUMPER ASSEMBLY	RATCHET EXTENSION
2	1	DRIVER MOUNT BOTTOM BRACKET	18 mm SOCKET
3	1	PASSENGER MOUNT BOTTOM BRACKET	15 mm SOCKET
4	1	DRIVER MOUNT FRAME BRACKET	10 mm SOCKET
5	1	PASSENGER MOUNT FRAME BRACKET	18 mm WRENCH
6	1	DRIVER UPPER STRAP	15mm WRENCH
7	1	PASSENGER UPPER STRAP	T10 TORX WRENCH
8	1	DRIVER LOWER STRAP	6 mm L WRENCH
9	1	PASSNEGER LOWER STRAP	5mm L WRENCH
10	1	DRIVER MOUNT SUPPORT STRAP	4 mm L WRENCH
11	1	PASSENGER MOUNT SUPPORT STRAP	FLAT SCREW DRIVER
12	1	CROSS TUBE MOUNT (INSTALL ONLY IF NOT INSTALLING WINCH)	
13	1	DRIVER WINCH TRAY SPACER (USED WITH PN 46-23955)	
14	1	PASSENGER WINCH TRAY SPACER (USED WITH PN 46-23955)	
15	2	THICK FLAT WASHER	
16	6	M12-1.75 x 35 HEX HEAD CAP SCREW	
17	2	M12 1.75 x 120 HEX HEAD CAP SCREW	
18	2	M10 1.5 x 120 HEX HEAD CAP SCREW	
19	4	M10 FLAT WASHER	
20	2	M10 SERRATED FLANGE NUT	
21	—	<i>— THIS SPACE WAS LEFT PURPOSELY BLANK —</i>	—
22	8	M12 FLAT WASHER	
23	4	M12 SERRATED FLANGE NUT	
24	4	M12 SPLIT LOCK WASER	
25	4	M12 - 37mm OD FLAT WASHER	
26	6	M10-1.50 x 35 HEX SOCKET BUTTON HEAD BOLT	
ANTI-SEIZE LUBRICANT MUST BE USED ON ALL STAINLESS STEEL FASTENERS TO PREVENT THREAD DAMAGE AND GALLING			

CONTENT

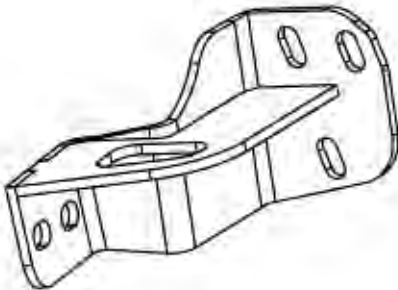
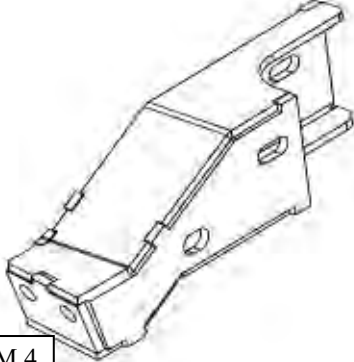
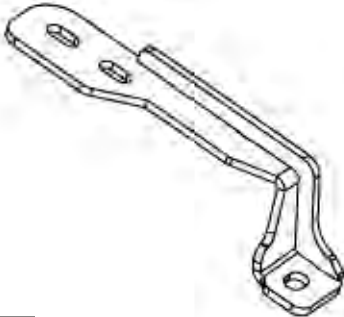
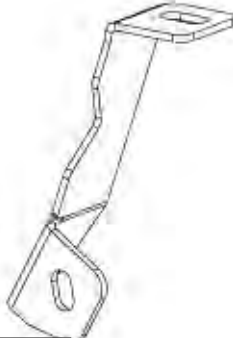
ITEM	QUANTITY	DESCRIPTION	TOOLS NEEDED
27	6	M10 BELLVILLE WASHER	
28	6	M10 SERRATED FLANGE NUT	
29	12	M12 - 1.75 x 35 HEX SOCKET BUTTON HEAD BOLT	
30	10	M12 SERRATED FLANGE NUT	
31	12	M12 BELLVILLE WASHER	

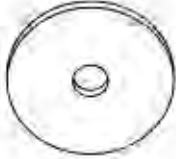
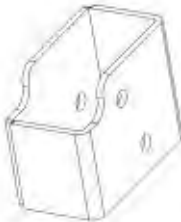
ANTI-SEIZE LUBRICANT MUST BE USED ON ALL STAINLESS STEEL FASTENERS TO PREVENT THREAD DAMAGE AND GALLING

 <p>ITEM 1</p>	 <p>ITEM 2</p>	 <p>ITEM 4</p>	
 <p>ITEM 6</p>	 <p>ITEM 8</p>	 <p>ITEM 10</p>	 <p>ITEM 15</p>
<p>Can be used with PN 46-23955</p>  <p>Item 13</p>	 <p>ITEM 12</p>		

Note:
****Vehicles with the optional safety package have front sensors that can only be disabled by adding the (KGU) Universal Vehicle Module (UVM) from GM.****

PROCEDURE

1. Remove contents from box, verify if all parts listed are present and free from damage.
Carefully read and understand all instructions before attempting installation.
Failure to identify damage before installation could lead to a rejection of any claim.
2. Begin by removing all plastic fasteners. See **Figure 1**.
3. Remove the two screws as seen in **Figure 2** using the Torx Wrench T10 screwdriver, once removed pull the lever towards you to remove. Remove plastic by pulling up.

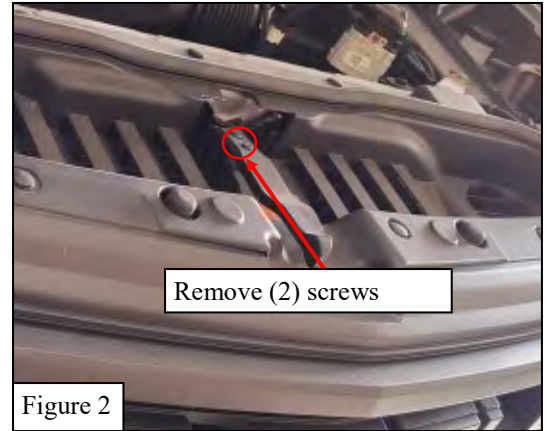

4. Remove the plastic fasteners holding the grille in place and detach the clips of the wings of the grille, as seen in **Figures 3 & 4**.

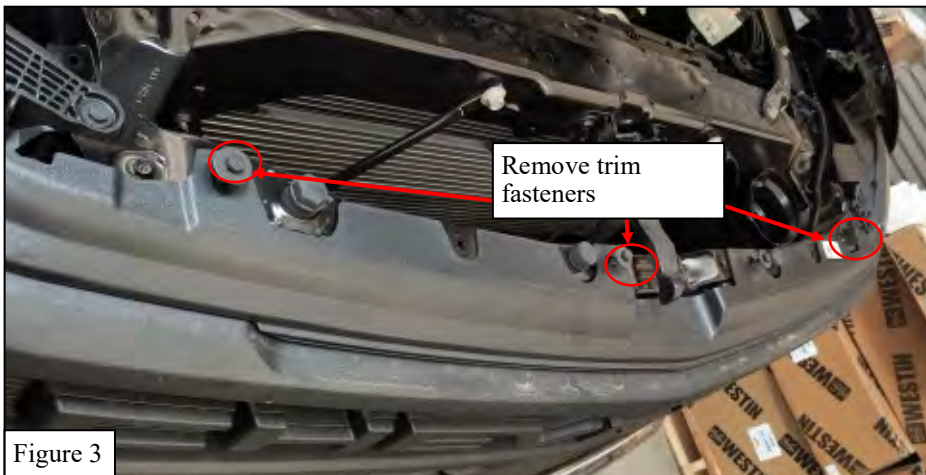

5. Remove the fasteners retaining the panel above the bumper from the inside of the wheel wells as seen in **Figure 5**.
6. Remove the trim panel from the clips near the headlights. Use a pry tool if necessary. See **Figure 6**.



7. On both sides of the vehicle, use a pry tool to remove the trim panel from the clips shown below. See **Figures 7-8**.
8. Remove the trim panel above the bumper.
9. Remove the fasteners retaining the grille.
10. Remove the grille from the clips above the headlights.
11. Remove the grille by loosen the top area, then firmly pulling it away from the vehicle.



12. Remove the (3) bolts from the bumper of the vehicle using a M10 Socket, see **Figure 9** for locations.

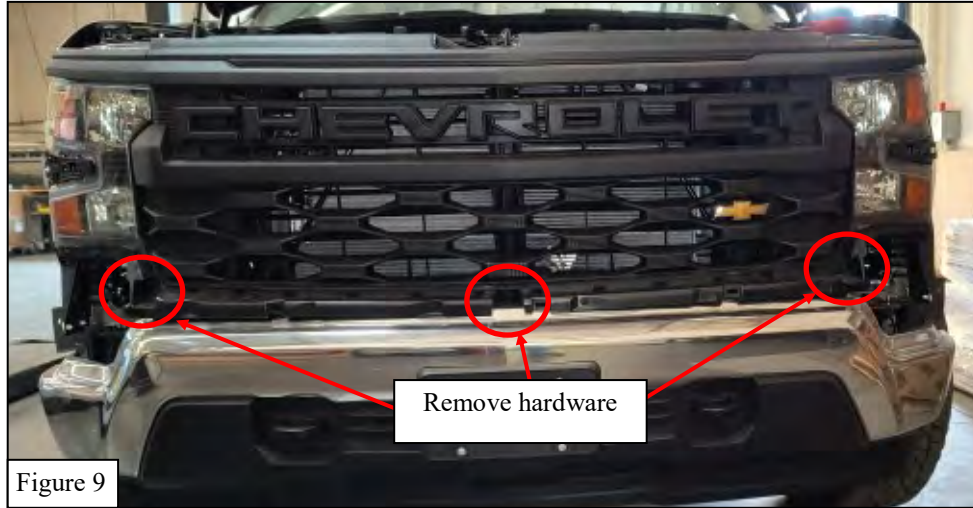

13. After removing the grille pull the plastic cover as seen on **Figure 10** up to detach the fasteners and remove plastic cover.
14. Remove (4) O.E. hardware located underneath the plastic cover that was removed. See **Figures 11&12**.
15. Remove (4) O.E. hardware attached to the plastic skid plate. See **Figure 13**.
16. Remove Bumper by carefully pulling it out.

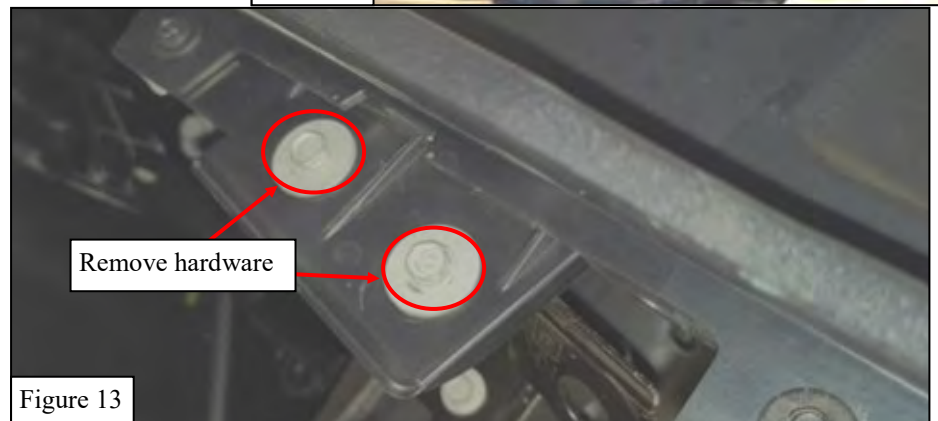
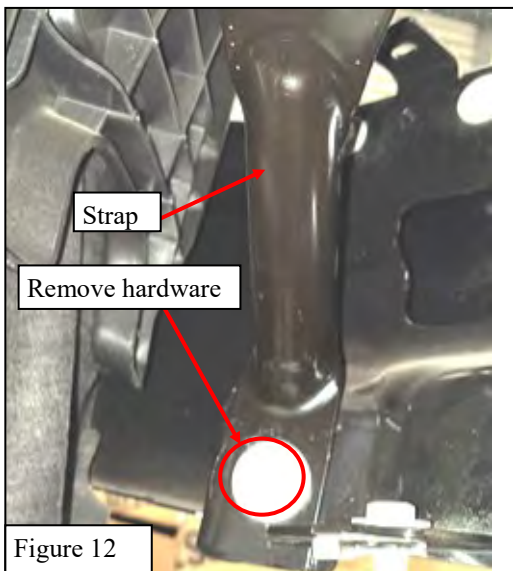
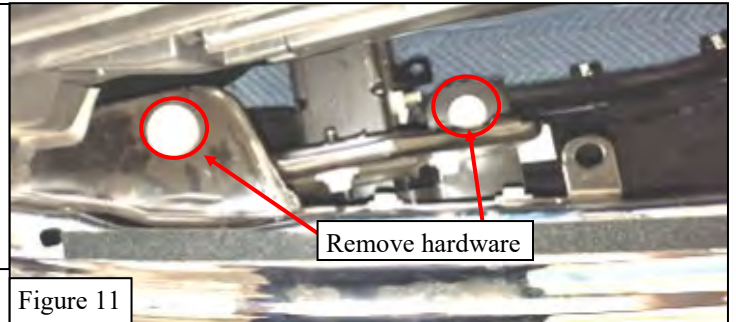
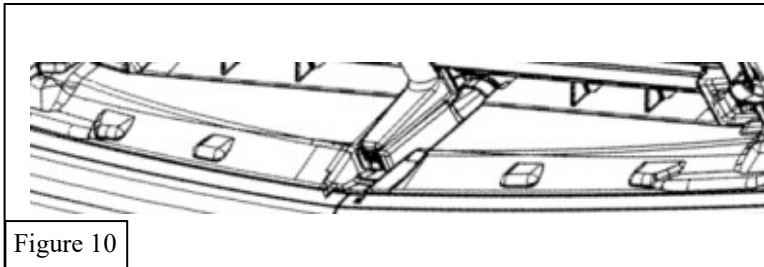

17. Once Bumper is removed slide in the Driver/Passenger Mount Frame Bracket (items 4&5) align all the holes and use M10 hex head hardware (items 18-20) as seen on **Figure 14**. Use M12 hex head hardware (items 16,22,&23) to install the Thick 7 GA Flat Washer (item 15). (If tow hooks are installed, please remove and discard them)
18. Loosely install Driver/Passenger Lower Strap (items 8 & 9) onto the case of the mount frame bracket using M12 hex head hardware (items 17,22,23,& 25). See **Figure 15 & 16** for reference and **Figure 19** for orientation.

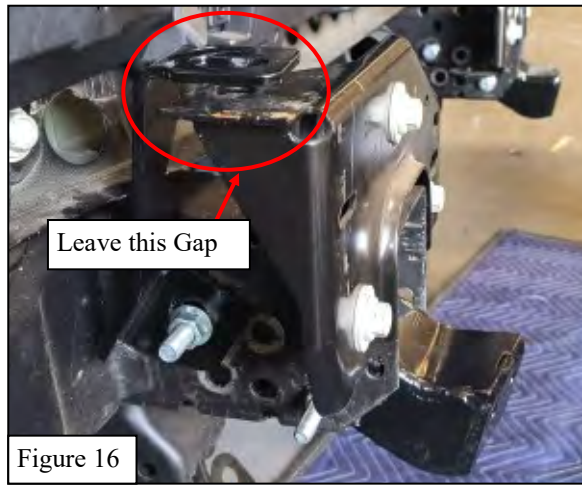
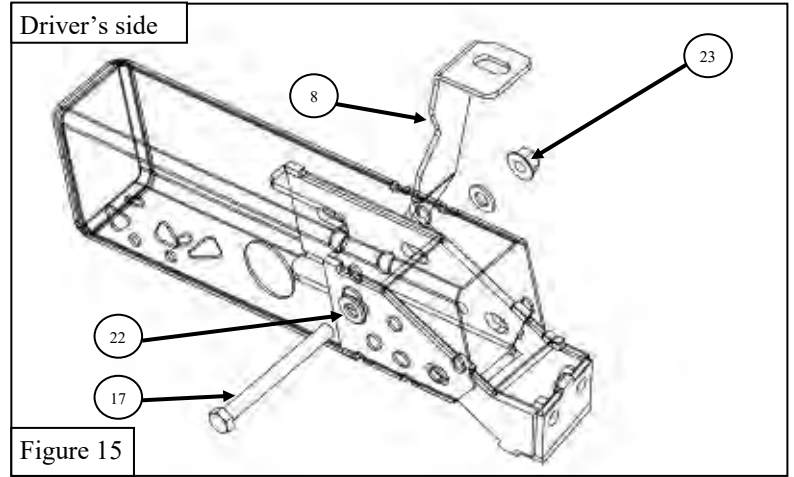
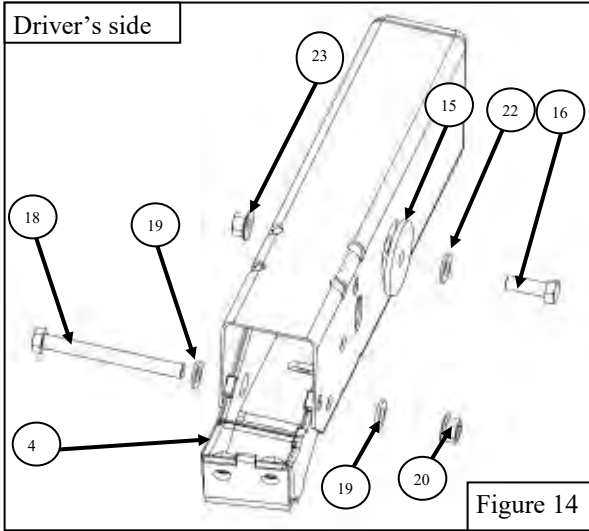

Note: If Pit Bar is being installed, refer to the installation sheet provided with Westin's Pit Bar to begin the installation process.

19. Re-install the bumper, without using the (2) top O.E bolts.
20. Cut the plastic piece that was removed, make 2 cuts the size in which the Upper Straps (items 6&7) rest without any interruptions. See **Figures 17 & 18**.

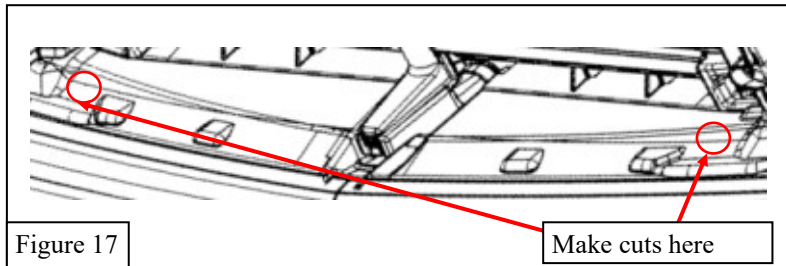

21. Once the piece is cut, reinstall the plastic piece as seen in **Figure 18** and install the Upper Straps (items 6 & 7) using the OEM hardware. See **Figure 18 & 19**.
22. Make sure the distance from the upper straps are at a distance of 40.13in. See **Figure 20**.

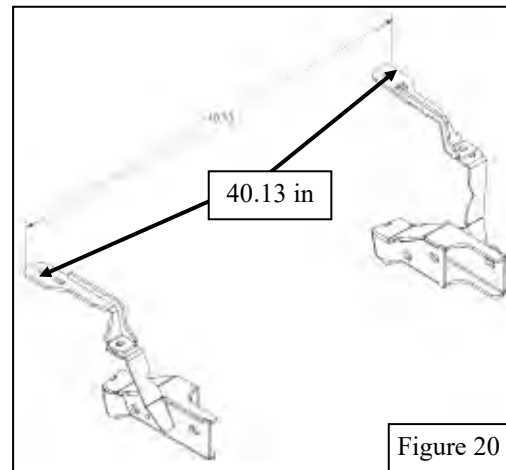
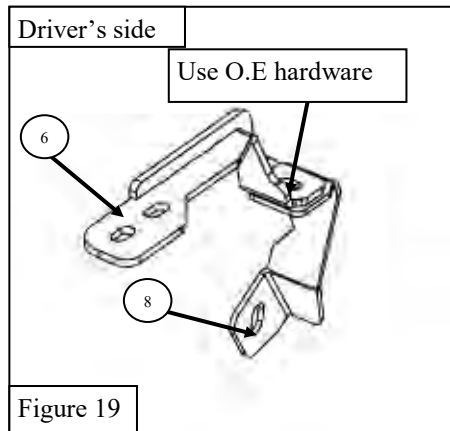

Only for Westin Winch Tray 46-23955

- Mount the Winch Tray Mounting Bracket (item 13) using M12 Buttonhead hardware. See **Figure 25** for Belleville washer orientation. Once mounted follow Westin Winch Tray instructions.

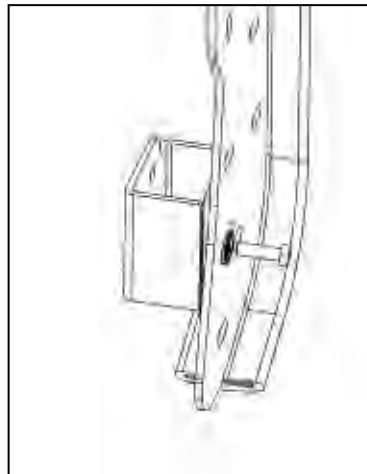

If Westin Winch not installed

- Mount the Cross Tube (item 12) to the Grille assembly using the M12 Hex socket button head hardware (items 29 & 31)

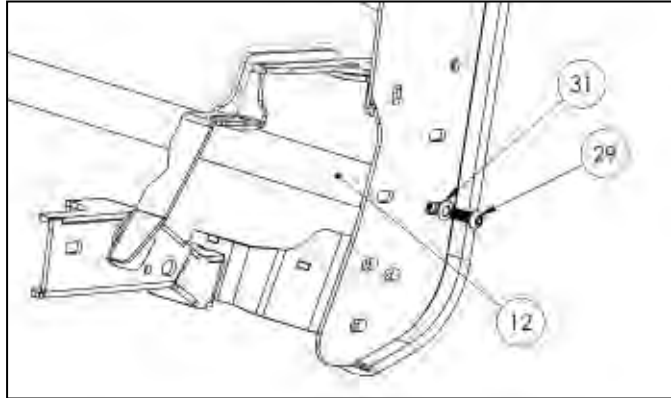

23. Reinstall the grille.
24. Reinstall the trim panel.
25. Once both are installed, loosely install the Mount Bottom Bracket (items 2 & 3) using the M12 hex head cap screw hardware (items 16,24, & 25). See **Figures 21 & 22**.
26. Install Cross Tube mount (item 12) using M12 (Only if Winch is not being installed)

Driver's side

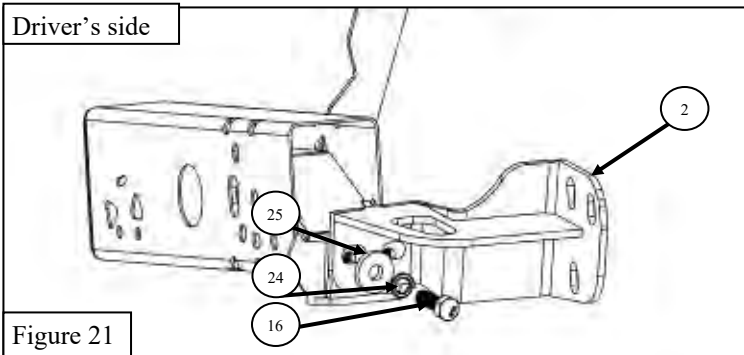

Figure 21

Driver's side

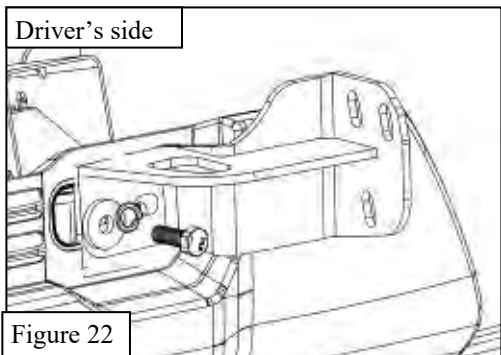

Figure 22

26. Install the Mount Support Strap (items 10&11) onto the Push Bumper Assembly (item 1) using the (2) M10 hex socket button head bolt hardware (items 26-28). See **Figure 23**.

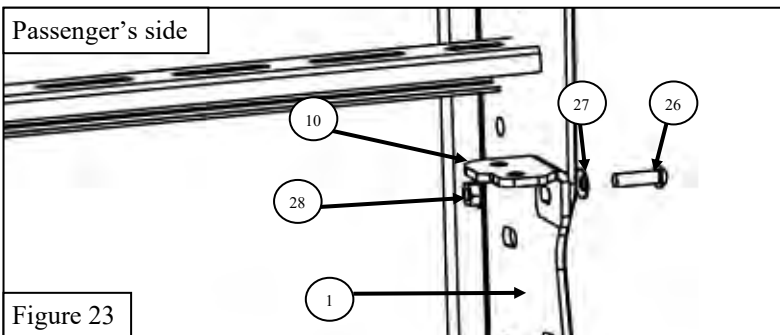
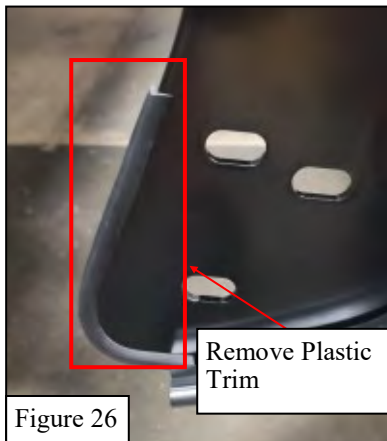
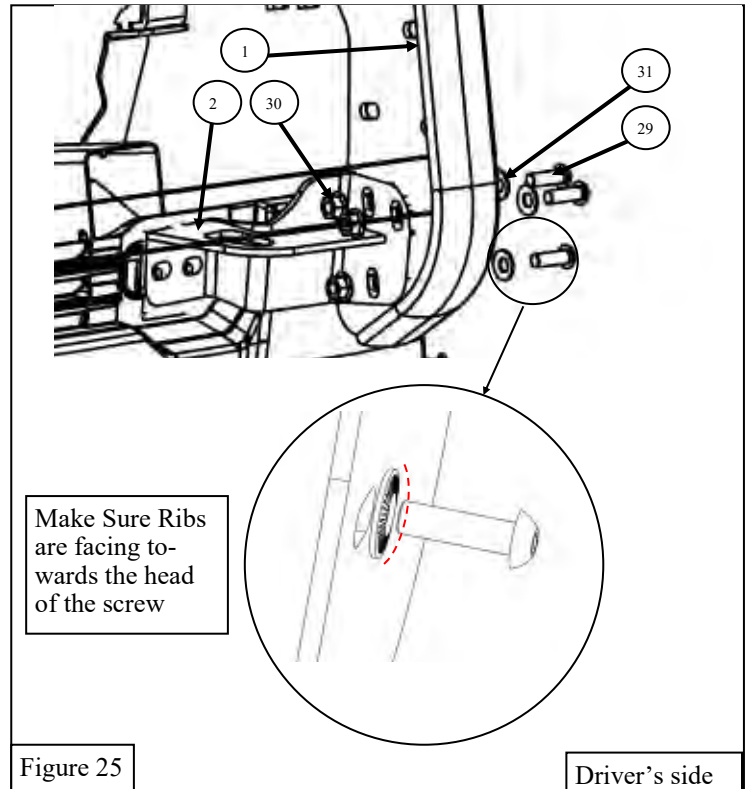
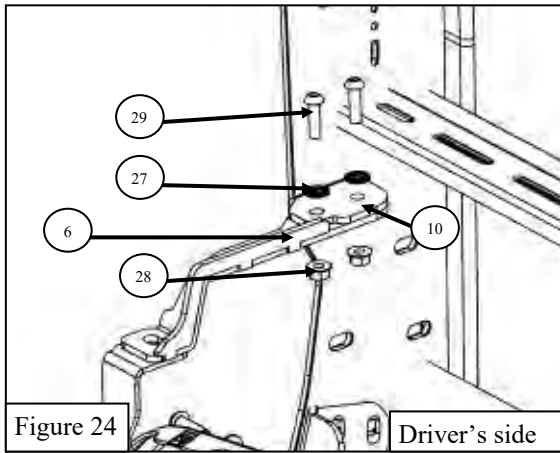

Figure 23

27. Install the Push Bumper (item 1) by aligning the Mount support strap (items 10 &11) and the Upper Strap (items 6 & 7) and connecting them using the M10 hex socket button head bolt hardware (items 27-29). See **Figure 24**.
28. Connect the Mount bottom bracket (items 2 & 3) and the Push Bumper (item 1) using the (3) M12 hex socket button head bolt hardware (items 30-32). See **Figure 25**.

Note: If rubber trim is part of the packaging, please discard. See **Figure 26**



INSTALLATION COMPLETE

**Image shows: 36-52135 installed with
36-52135PB and 36-52135W**



CARE INSTRUCTIONS

- REGULAR WAXING IS RECOMMENDED. DO NOT USE ANY TYPE OF POLISH OR WAX THAT MAY CONTAIN ABRASIVES.
- STAINLESS STEEL PRODUCTS CAN BE CLEANED WITH MILD SOAP AND WATER. STAINLESS STEEL POLISH SHOULD BE USED TO POLISH SMALL SCRATCHES.
- GLOSS BLACK FINISHES SHOULD BE CLEANED WITH MILD SOAP AND WATER.

WESTIN Westin Automotive Products, Inc.
320 W. Covina Blvd
San Dimas, Ca. 91773

**Thank you for choosing Westin products
for additional installation assistance please call
Customer Service (800) 793-7846
www.westinautomotive.com**



WARNING



Failure to follow these instructions could lead to death, personal injury, and / or property damage.

Failure to follow these instructions could lead to death, personal injury, and / or property damage.

FASTENERS:

All Westin supplied fasteners must be utilized and installed in accordance with the installation instructions and apply torque to the specifications as defined. **DOUBLE CHECK ALL FASTENERS BEFORE INITIAL USE, AND PERIODICALLY IN THE FUTURE TO ENSURE PROPER FUNCTION AND SAFETY.**

DRILLING:

Most Westin products do not require drilling for installation. If drilling is defined as required, use caution when drilling a vehicle. **FAILURE TO REVIEW AN AREA TO BE DRILLED MAY RESULT IN PERSONAL INJURY AND/OR INJURY TO OTHERS AS WELL AS VEHICLE DAMAGE.**

EYE PROTECTION:

ALWAYS WEAR SAFETY GLASSES OR GOGGLES DURING THE INSTALLATION PROCESS TO AVOID PERSONAL INJURY.

MAXIMUM TOWING/CARRYING CAPACITY: (if applicable)

The Westin Receiver Hitches will have a visible tow rating label affixed directly on the product. User should never exceed the vehicle manufacturers maximum tow and weight rating regardless of the capacity of the hitch. **FAILURE TO FOLLOW THESE GUIDELINES WILL VOID THE WESTIN WARRANTY AND MAY RESULT IN PERSONAL INJURY AND/OR INJURY TO OTHERS AS WELL AS VEHICLE DAMAGE.**

FOR CALIFORNIA RESIDENTS ONLY-PROP 65 WARNING:

Some products may contain chemicals such as DEHP, which can cause cancer, birth defects or other reproductive harm. For more info go to www.p65warnings.ca.gov



Westin Automotive Products, Inc.
320 W. Covina Blvd
San Dimas, Ca. 91773