

# INSTALLATION INSTRUCTIONS



## ELITE UPRIGHT WIRE COVER

**APPLICATION:**  
Accessory for 36-4045 Push Bumper Elite  
2021 TAHOE PPV  
**PART NUMBER:**  
36-4045WC

CONTENT			
ITEM	QUANTITY	DESCRIPTION	TOOLS NEEDED
1	1	WIRE COVER—DRIVER	15MM SOCKET
2	1	WIRE COVER—PASSENGER	RATCHET
3	4	M6 SOCKET BUTTON HEAD SCREW	5MM “L” WRENCH
4	4	M6 LOCK WASHER	4MM “L” WRENCH
5	4	M6 FLAT WASHER, 18MM OD	
6	2	M6 U-CLIP	
7	2	M-6 FLANGE NUT	
8	2	M10 SOCKET BUTTON HEAD SCREW	
9	2	M10 FLAT WASHER	
10	2	M10 FLANGE NUT	

**ANTI-SEIZE LUBRICANT MUST BE USED ON ALL STAINLESS STEEL FASTENERS TO PREVENT THREAD DAMAGE AND GALLING**

**THIS PRODUCT CAN BE INSTALLED ONLY ON WESTIN PUSH BUMPER ELITE 36-4045.**

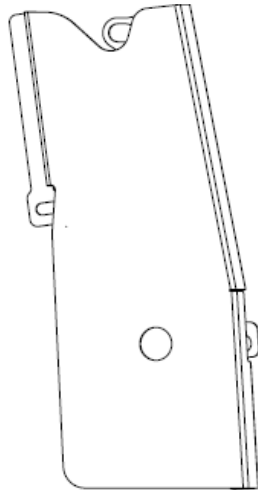

ITEM 1

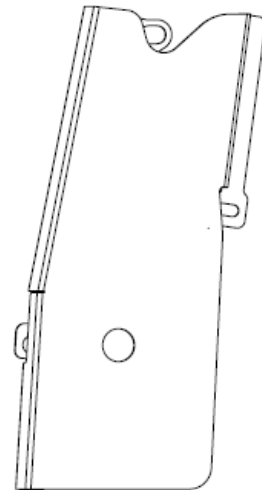

ITEM 2

## PROCEDURE

1. Remove contents from box, verify if all parts listed are present and free from damage.  
Carefully read and understand all instructions before attempting installation.  
**Failure to identify damage before installation could lead to a rejection of any claim.**
2. Install U-clip (6) on wire cover as shown in figure 1. Driver side shown.
3. Place wire covers (1 & 2) as shown in figure 2.
4. Install M6 flange nut (7) and M10 flange nut (10) as shown in figure 2.
5. Install M10 Hardware (8 & 9) and M6 hardware (5, 4, & 3) as shown in figure 3.
6. Tighten hardware to: M6 hardware to 8 ft-lb, and M10 hardware to 30 ft-lb.

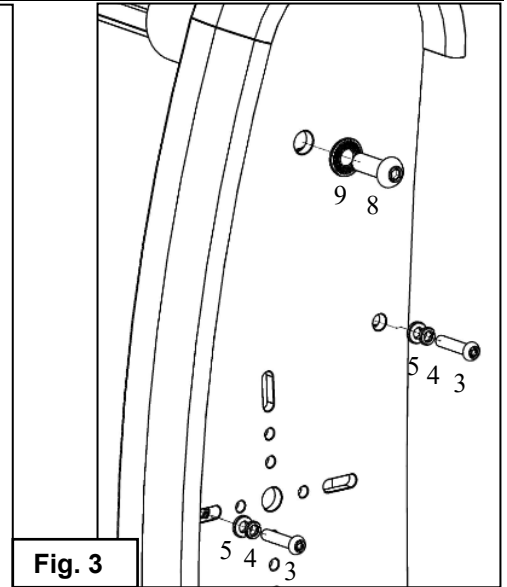
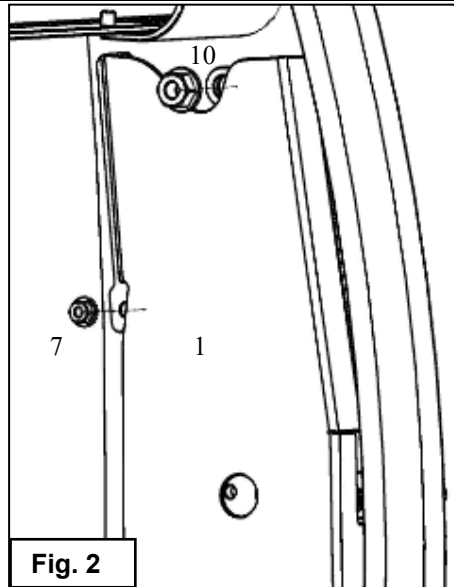
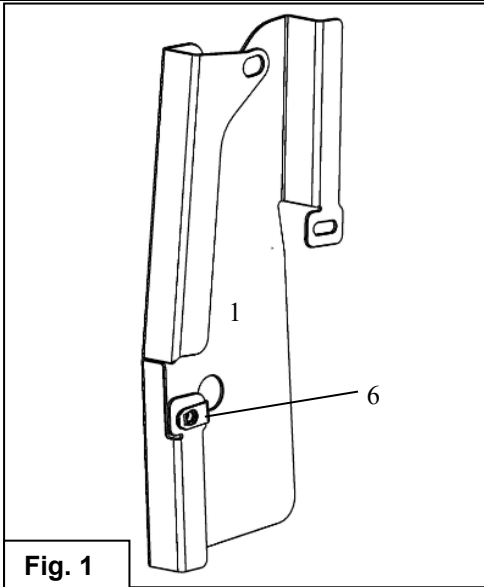

INSTALLATION COMPLETED



## CARE INSTRUCTIONS

- REGULAR WAXING IS RECOMMENDED. DO NOT USE ANY TYPE OF POLISH OR WAX THAT MAY CONTAIN ABRASIVES
- STAINLESS STEEL PRODUCTS CAN BE CLEANED WITH MILD SOAP AND WATER. STAINLESS STEEL POLISH SHOULD BE USED TO POLISH SMALL SCRATCHES.
- GLOSS BLACK FINISHES SHOULD BE CLEANED WITH MILD SOAP AND WATER

**WESTIN** Westin Automotive Products, Inc.  
320 W. Covina Blvd  
San Dimas, Ca. 91773

Thank you for choosing Westin products  
for additional installation assistance please call  
Customer Service (800) 793-7846

[www.westinautomotive.com](http://www.westinautomotive.com)

DATE: 01/14/2021



## WARNING



Failure to follow these instructions could lead to death, personal injury, and / or property damage.

Failure to follow these instructions could lead to death, personal injury, and / or property damage.

### FASTENERS:

All Westin supplied fasteners must be utilized and installed in accordance with the installation instructions and apply torque to the specifications as defined. **DOUBLE CHECK ALL FASTENERS BEFORE INITIAL USE, AND PERIODICALLY IN THE FUTURE TO ENSURE PROPER FUNCTION AND SAFETY.**

### DRILLING:

Most Westin products do not require drilling for installation. If drilling is defined as required, use caution when drilling a vehicle. **FAILURE TO REVIEW AN AREA TO BE DRILLED MAY RESULT IN PERSONAL INJURY AND/OR INJURY TO OTHERS AS WELL AS VEHICLE DAMAGE.**

### EYE PROTECTION:

**ALWAYS WEAR SAFETY GLASSES OR GOGGLES DURING THE INSTALLATION PROCESS TO AVOID PERSONAL INJURY.**

### MAXIMUM TOWING/CARRYING CAPACITY: (if applicable)

The Westin Receiver Hitches will have a visible tow rating label affixed directly on the product. User should never exceed the vehicle manufacturers maximum tow and weight rating regardless of the capacity of the hitch. **FAILURE TO FOLLOW THESE GUIDELINES WILL VOID THE WESTIN WARRANTY AND MAY RESULT IN PERSONAL INJURY AND/OR INJURY TO OTHERS AS WELL AS VEHICLE DAMAGE.**

### FOR CALIFORNIA RESIDENTS ONLY-PROP 65 WARNING:

Some products may contain chemicals such as DEHP, which can cause cancer, birth defects or other reproductive harm. For more info go to [www.p65warnings.ca.gov](http://www.p65warnings.ca.gov)



Westin Automotive Products, Inc.  
320 W. Covina Blvd  
San Dimas, Ca. 91773