

# INSTALLATION INSTRUCTIONS

## PUSH BUMPER ELITE

### APPLICATION:

TAHOE 2021-2024 POLICE PURSUIT VEHICLE

### PART NUMBER:

36-4045



CONTENT			
ITEM	QUANTITY	DESCRIPTION	TOOLS NEEDED
1	1	PUSH BAR	UTILITY KNIFE
2	1	BRACKET DRIVER	SCREWDRIVER
3	1	PASSENGER BRACKET	18MM WRENCH
4	1	DRIVER CLAMP BRACKET	18MM SOCKET
5	1	PASSENGER CLAMP BRACKET	15MM WRENCH
6	1	DRIVER EXTENSION BRACKET	15MM SOCKET
7	1	PASSENGER EXTENSION BRACKET	10MM SOCKET
8	1	DRIVER UPPER BRACKET	7MM SOCKET
9	1	PASSENGER UPPER BRACKET	T15 TORX BIT
10	2	M10 BUTTON HEAD BOLT	8 MM ALLEN WRENCH
11	2	M10 BELLVILLE WASHER	6 MM ALLEN WRENCH
12	2	M10 SERRATED FLANGE HEX NUT	RATCHET
13	10	M12 BUTTON HEAD BOLT	RATCHET EXT.
14	10	M12 BELLVILLE WASHER	TORQUE WRENCH
15	10	M12 SERRATED FLANGE HEX NUT	HAMMER
16	4	M12 HEX HEAD BOLT—LONG	
17	6	M12 HEX HEAD BOLT—SHORT	
18	10	M12 SERRATED FLANGE NUT—YELLOW	
19	10	M12 FLAT WASHER	
20	1	DRIVER TEMPLATE	
21	1	PASSENGER TEMPLATE	

**ANTI-SEIZE LUBRICANT MUST BE USED ON ALL STAINLESS STEEL FASTENERS TO PREVENT THREAD DAMAGE AND GALLING**

**IMPORTANT NOTICE: PUSH BUMPER WILL INTERFERE WITH FRONT PARK ASSIST SENSORS.**  
IF VEHICLE IS EQUIPED WITH FRONT PARK ASSIST SENSORS, VEHICLE WILL NEED DEALER REFLASH CALIBRATION  
“SERVICE CAL SK5” TO DISABLE THE FRONT PARK ASSIST.

**NOTE: IF INSTALLING BUMPER IN A CIVILIAN VEHICLE IT WILL NOT WORK WITH CRUISE CONTROL SENSORS.**

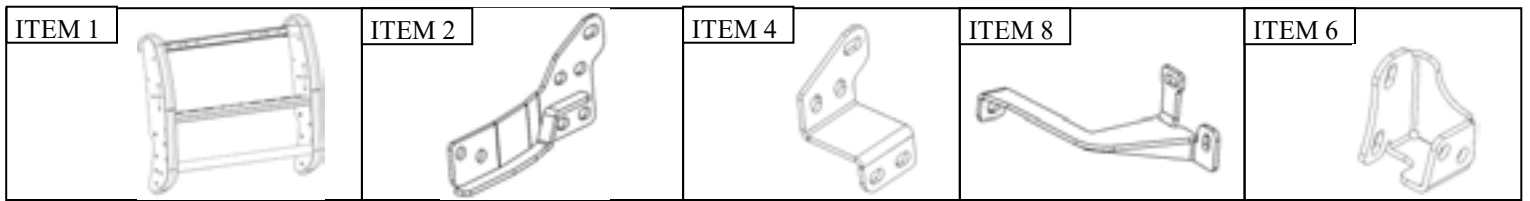

**WESTIN** Westin Automotive Products, Inc.  
320 W. Covina Blvd  
San Dimas, Ca. 91773

Thank you for choosing Westin products  
for additional installation assistance please call  
Customer Service (800) 793-7846

www.westinautomotive.com

DATE: 07/24/2024

## PROCEDURE

1. Remove contents from box, verify if all parts listed are present and free from damage. Carefully read and understand all instructions before attempting installation.  
**Failure to identify damage before installation could lead to a rejection of any claim.**
2. Follow the next steps to remove the entire front grille and fascia from the front of the vehicle. There are a number of plastic fasteners and metal screws holding it on. Care should be taken not to damage the fascia as it is removed.
3. Open the hood and remove the 9 plastic rivets and the two screws with the plastic hood release handle (**Figure 1**) and remove the top plastic cover, then remove the screws holding the grill (**Figure 2**).
5. Remove screws located under the fenders that holds the front fascia (**Figure 5**). Carefully pull the fender trim. Remove all the screws under the vehicle to loosen the bottom part of the fascia. (**Figures 3 & 4**)
6. On a civilian vehicle (not Z71) Remove the bolt behind the bumper under the chassis on each side of the vehicle. **Figure 6.**
7. Remove screw under each side of the fenders. (**Figures 7 & 8**).



FIGURE 1



FIGURE 2



FIGURE 3



FIGURE 4



FIGURE 5



FIGURE 6

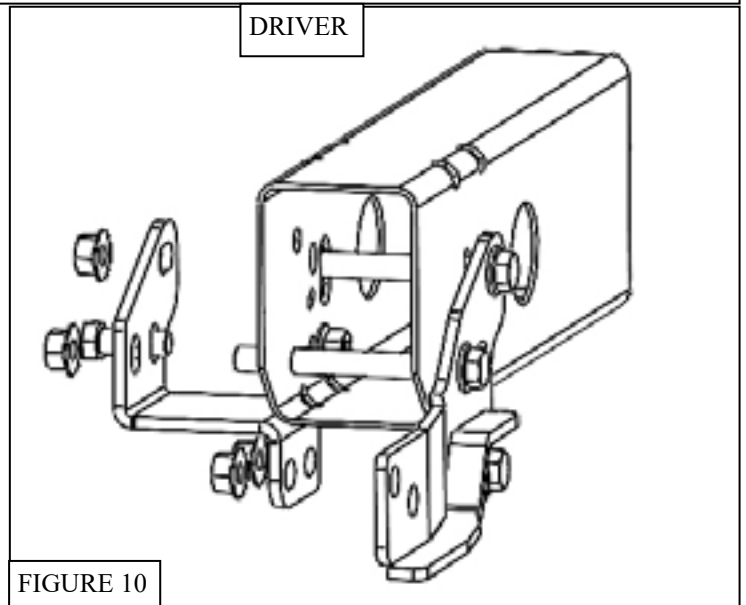
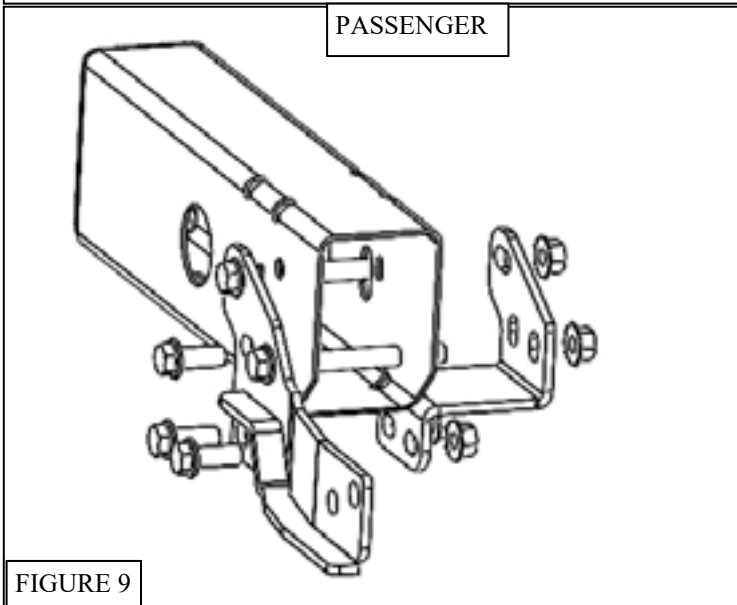

FIGURE 7

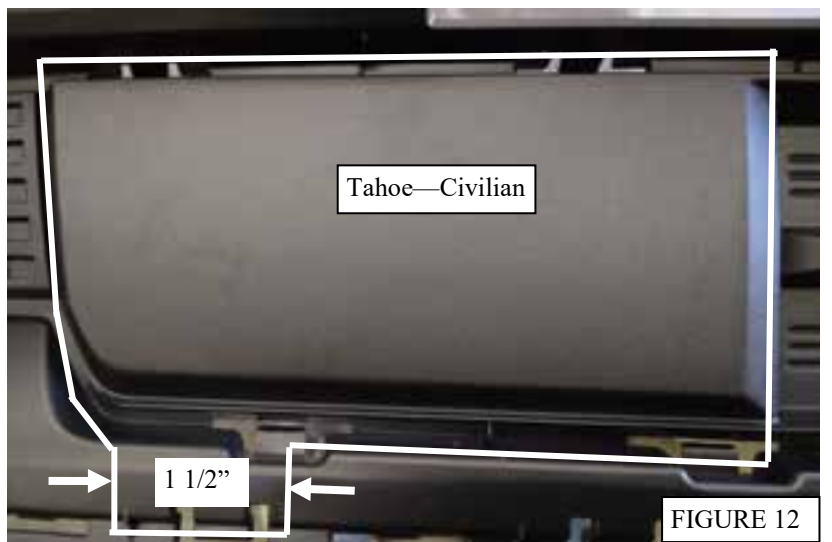

FIGURE 8

8. With help disconnect any connection from the fascia to the vehicle and carefully disengage the whole front fascia.
9. Pull the plastic cover on top of the internal bumper and from radiator support and discard it.
10. If equipped with tow hooks remove them and save them with their hardware to be reuse with the mounting brackets installation in the following step.
11. Install driver (2) and passenger (3) brackets to the chassis using the clamp brackets (4 & 5), 4 M12 hex bolts long (16), 6 M12 hex bolts short (17), 10 M12 flat washers (19), and 10 M12 flange nuts (18), Reuse the factory bolt with the outer clamp bracket. Leave them loose for now. **(Figures 9 & 10). Note: Chassis mount holes are not mirrored to each other. Please refer to Figures 9 & 10.**
12. Tighten M12 hardware to 50-55 ft-lbs.,
13. **Do not install upper mounting brackets yet! Note: If installing the Pit Bar, refer to Install sheet PN 75-364045PB.**



14. Before installing the front fascia, trim the lower grille slots as shown in the images below. Note: **Figure 11** is for the Police vehicle and **Figure 12** is for the civilian vehicle.



15. Reinstall the front Fascia

16. Install the extension brackets (6 & 7) (**Figure 13**) using M12 button head bolts (13) M12 Bellville washer (14) and M12 serrated flange nut (15) leave hardware loose for now.

17. Install the push bumper (1) (**Figure 13**) using M12 button head bolts (13) M12 Bellville washers (14) and M12 serrated flange nuts (15). Slightly tighten hardware for now to secure the push bumper.

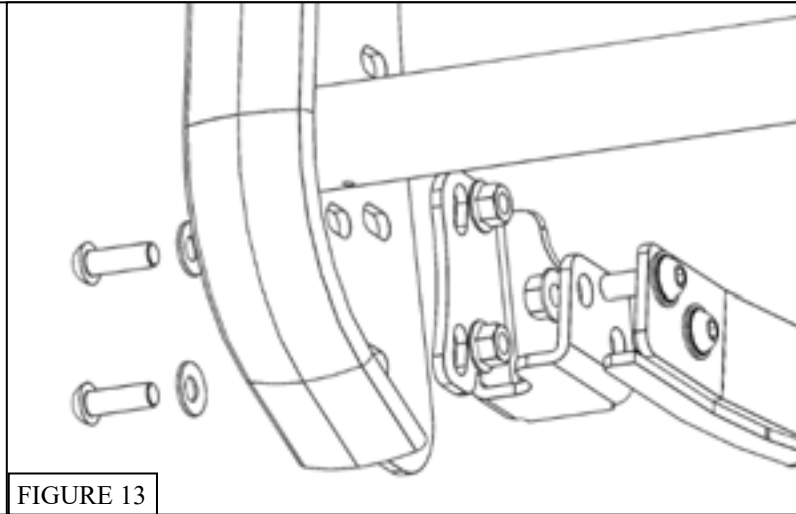

FIGURE 13

18. Using the provided template (20 & 21), cut at the dotted lines and place the indicated side at 2" from the center of the fascia and the top edge of the bumper, close to the edge of the grill, carefully drill a 2" hole at each side of the fascia. (**Figure 14**) Carefully clean the hole edges.

19. Remove the stock bolt shown in **Figure 15** and save it to be used in the next step.

20. Place the upper brackets into the holes and install them using the previously removed bolts. (**Figure 15**) leave them loose for now.

21. Using the M10 hardware (10, 11, and 12) and M12 Hardware (13, 14, and 15) install the upper brackets (8 & 9) to the push bumper. (**Figure 15**)

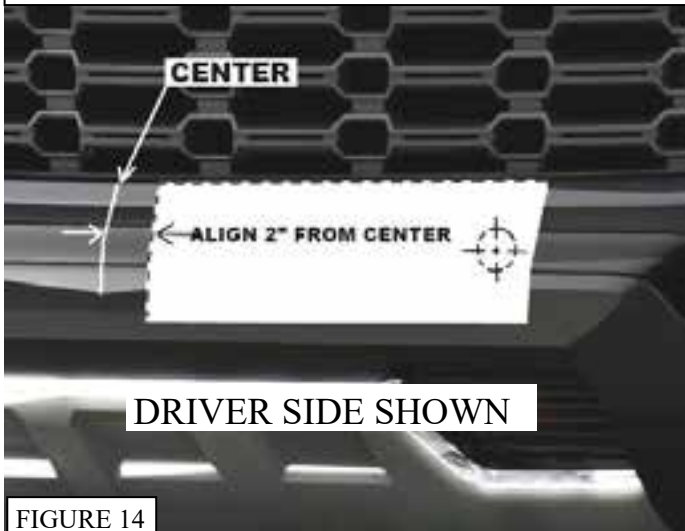

FIGURE 14

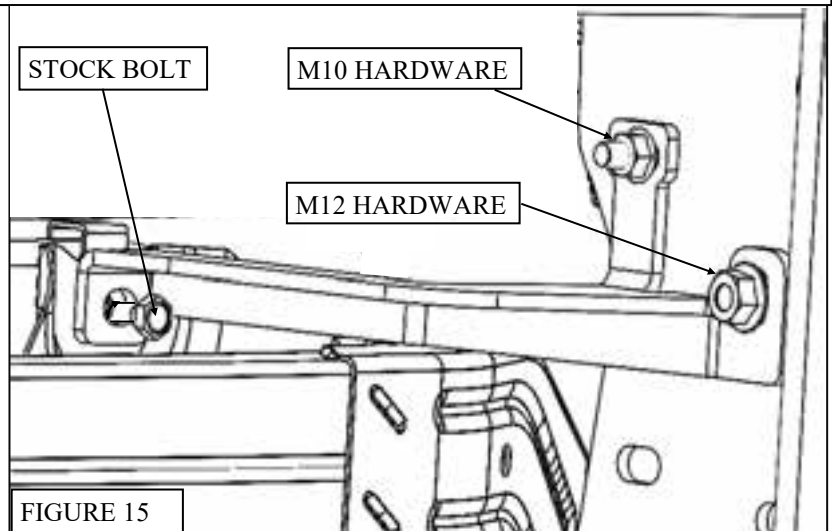

FIGURE 15

22. Align and adjust the Push Bumper as necessary. Tighten all remaining fasteners M12 to 50-55 ft-lbs., M10 to 30-35 ft-lbs.

INSTALLATION COMPLETE



Pit Bars 36-4045PB and Wing Wraps 36-4045W Sold Separately

#### CARE INSTRUCTIONS

- REGULAR WAXING IS RECOMMENDED. DO NOT USE ANY TYPE OF POLISH OR WAX THAT MAY CONTAIN ABRASIVES.
- STAINLESS STEEL PRODUCTS CAN BE CLEANED WITH MILD SOAP AND WATER. STAINLESS STEEL POLISH SHOULD BE USED TO POLISH SMALL SCRATCHES.
- GLOSS BLACK FINISHES SHOULD BE CLEANED WITH MILD SOAP AND WATER.

**WESTIN**

Westin Automotive Products, Inc.  
320 W. Covina Blvd  
San Dimas, Ca. 91773

Thank you for choosing Westin products  
for additional installation assistance please call  
Customer Service (800) 793-7846  
[www.westinautomotive.com](http://www.westinautomotive.com)



## WARNING



Failure to follow these instructions could lead to death, personal injury, and / or property damage.

Failure to follow these instructions could lead to death, personal injury, and / or property damage.

### FASTENERS:

All Westin supplied fasteners must be utilized and installed in accordance with the installation instructions and apply torque to the specifications as defined. **DOUBLE CHECK ALL FASTENERS BEFORE INITIAL USE, AND PERIODICALLY IN THE FUTURE TO ENSURE PROPER FUNCTION AND SAFETY.**

### DRILLING:

Most Westin products do not require drilling for installation. If drilling is defined as required, use caution when drilling a vehicle. **FAILURE TO REVIEW AN AREA TO BE DRILLED MAY RESULT IN PERSONAL INJURY AND/OR INJURY TO OTHERS AS WELL AS VEHICLE DAMAGE.**

### EYE PROTECTION:

**ALWAYS WEAR SAFETY GLASSES OR GOGGLES DURING THE INSTALLATION PROCESS TO AVOID PERSONAL INJURY.**

### MAXIMUM TOWING/CARRYING CAPACITY: (if applicable)

The Westin Receiver Hitches will have a visible tow rating label affixed directly on the product. User should never exceed the vehicle manufacturers maximum tow and weight rating regardless of the capacity of the hitch. **FAILURE TO FOLLOW THESE GUIDELINES WILL VOID THE WESTIN WARRANTY AND MAY RESULT IN PERSONAL INJURY AND/OR INJURY TO OTHERS AS WELL AS VEHICLE DAMAGE.**

### FOR CALIFORNIA RESIDENTS ONLY-PROP 65 WARNING:

Some products may contain chemicals such as DEHP, which can cause cancer, birth defects or other reproductive harm. For more info go to [www.p65warnings.ca.gov](http://www.p65warnings.ca.gov)



Westin Automotive Products, Inc.  
320 W. Covina Blvd  
San Dimas, Ca. 91773