

INSTALLATION INSTRUCTIONS



PUSH BUMPER ELITE WIRE COVER
APPLICATION:
 Accessory for 36-2035 Push Bumper Elite
PART NUMBER:
 36-2035WC

CONTENT			
ITEM	QUANTITY	DESCRIPTION	TOOLS NEEDED
1	1	WIRE COVER—DRIVER	15MM SOCKET
2	1	WIRE COVER—PASSENGER	RATCHET
3	2	M6 SOCKET BUTTON HEAD SCREW	6MM “L” WRENCH
4	2	M6 LOCK WASHER	4MM “L” WRENCH
5	2	M6 FLAT WASHER, 18MM OD	
6	2	M10 SOCKET BUTTON HEAD SCREW	
7	2	M10 FLAT WASHER 20MM OD	
8	2	M10 SERRATED FLANGE NUT	
9	2	M6 U-CLIP NUT	
		--	
		--	

ANTI-SEIZE LUBRICANT MUST BE USED ON ALL STAINLESS STEEL FASTENERS TO PREVENT THREAD DAMAGE AND GALLING

THIS PRODUCT CAN BE INSTALLED ONLY ON WESTIN PUSH BUMPER ELITE 36-2035.

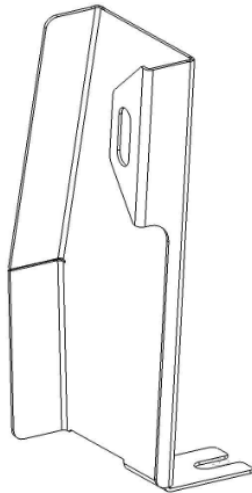

ITEM 1

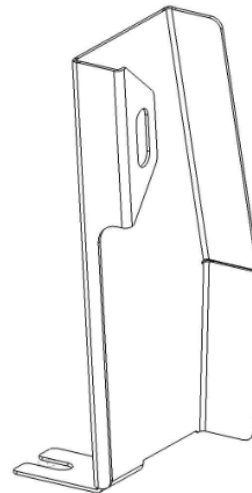

ITEM 2

PROCEDURE

1. Remove contents from box, verify if all parts listed are present and free from damage.
Carefully read and understand all instructions before attempting installation.
Failure to identify damage before installation could lead to a rejection of any claim.
2. U-clip (9) on each wire cover as shown in figures 1 & 5
3. Place wire covers 1 & 2 as shown in figure 2.
4. Install M10 hardware 6, 7, & 8 as shown in figure 2, 4 & 5.
5. Install M6 hardware as shown in figure 3, 4 & 5.
6. Tighten hardware to: M6 hardware to 6-8 ft-lbs, and M10 hardware to 51-56 ft-lbs

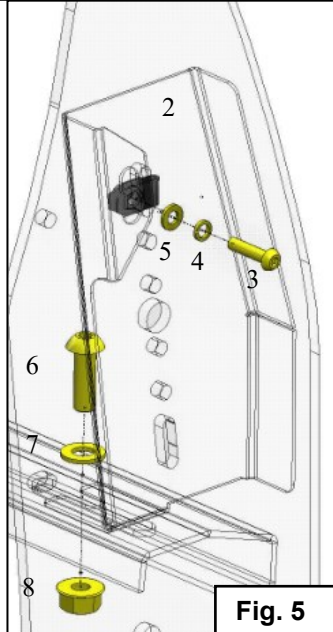
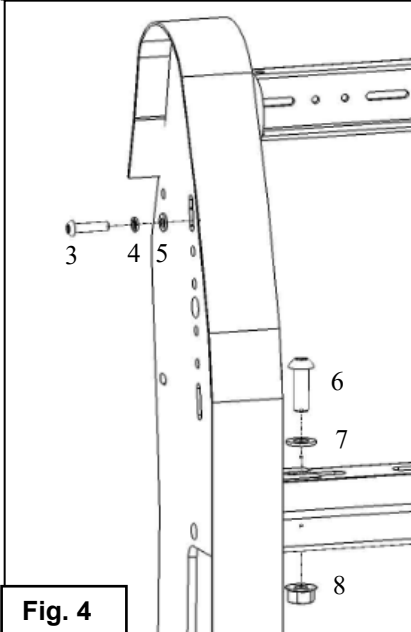
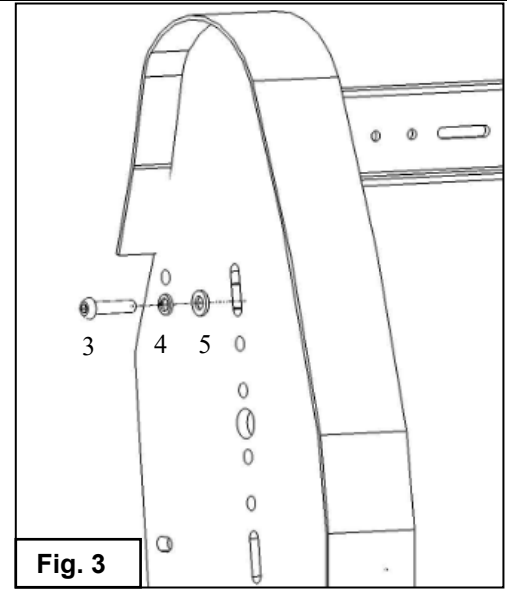
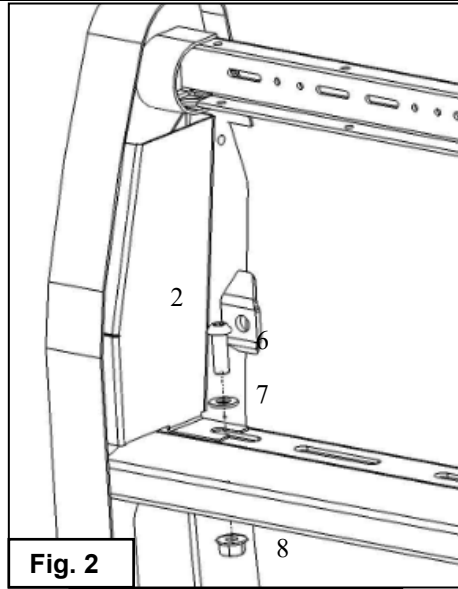
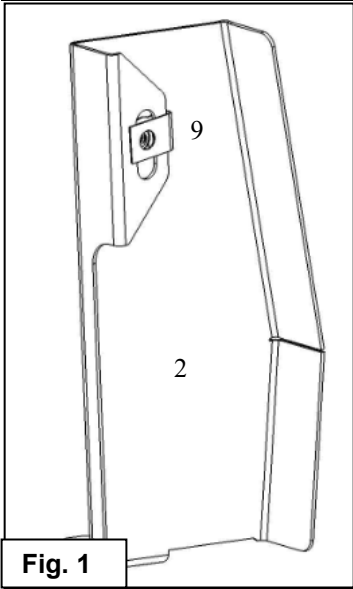

INSTALLATION COMPLETED



CARE INSTRUCTIONS

- REGULAR WAXING IS RECOMMENDED. DO NOT USE ANY TYPE OF POLISH OR WAX THAT MAY CONTAIN ABRASIVES
- STAINLESS STEEL PRODUCTS CAN BE CLEANED WITH MILD SOAP AND WATER. STAINLESS STEEL POLISH SHOULD BE USED TO POLISH SMALL SCRATCHES.
- GLOSS BLACK FINISHES SHOULD BE CLEANED WITH MILD SOAP AND WATER



SIGNATURE OF QUALITY

AUTOMOTIVE PRODUCTS, INC.

WARNINGS & NOTICES FOR THE INSTALLATION OF WESTIN TOWING PRODUCTS - CLASS III RECEIVER HITCH

NOTICE

Westin Receiver Hitches are designed to accommodate a 2"- square receiver draw bar rated for class III/IV towing. Closely follow all Westin Installation Instructions for the proper installation of product. Improper installation can result in death, serious injury, and/or product and vehicle damage. In the operation of these products, it is imperative to observe precautions for your personal safety and the safety of others.



WARNING



Failure to follow these instructions could lead to death, personal injury, and / or property damage.

FASTENERS:

All Westin supplied fasteners must be utilized and installed in accordance with the installation instructions and apply torque to the specifications as defined. **DOUBLE CHECK ALL FASTENERS BEFORE INITIAL USE, AND PERIODICALLY IN THE FUTURE TO ENSURE PROPER FUNCTION AND SAFETY.**

DRILLING:

Most Westin products do not require drilling for installation. If drilling is defined as required, use caution when drilling a vehicle. **FAILURE TO REVIEW AN AREA TO BE DRILLED MAY RESULT IN PERSONAL INJURY AND/OR INJURY TO OTHERS AS WELL AS VEHICLE DAMAGE.**

EYE PROTECTION:

ALWAYS WEAR SAFETY GLASSES OR GOGGLES DURING THE INSTALLATION PROCESS TO AVOID PERSONAL INJURY.

MAXIMUM TOWING/CARRYING CAPACITY:

The Westin Receiver Hitches will have a visible tow rating label affixed directly on the product. User should never exceed the vehicle manufacturers maximum tow and weight rating regardless of the capacity of the hitch. **FAILURE TO FOLLOW THESE GUIDELINES WILL VOID THE WESTIN WARRANTY AND MAY RESULT IN PERSONAL INJURY AND/OR INJURY TO OTHERS AS WELL AS VEHICLE DAMAGE.**



Westin Automotive Products, Inc.
320 W. Covina Blvd
San Dimas, Ca. 91773

Thank you for choosing Westin products
for additional installation assistance please call
Customer Service (800) 793-7846

www.westinautomotive.com

DATE: 04/18/2019