



AUTOMOTIVE PRODUCTS, INC.

INSTALLATION INSTRUCTIONS

PUSH BUMPER ELITE
FORD POLICE INTERCEPTOR UTILITY (2016–2019)
APP PART # 36-2055

ITEM	QUANTITY	DESCRIPTION	TOOLS NEEDED
1	1	PUSH BAR ASSEMBLY	RATCHET
2,3	2	LOWER MOUNTING BRACKETS (DRV & PASS)	SCREWDRIVER
4,5	2	CLAMP BRACKETS (DRV & PASS)	14MM WRENCH
6,7	2	UPPER MOUNTING BRACKETS (DRV & PASS)	14MM SOCKET
8	4	M12 CUPPED WASHER (BLACK PLATED S/S)	ALLEN WRENCH
9	4	M12 FLANGE NUT (BLACK PLATED S/S)	18MM WRENCH
10	4	M12 HEX SOCKET BUTTON HEAD SCREW (BLACK PLATED S/S)	15MM SOCKET
11	2	M10 CUPPED WASHER (BLACK PLATED S/S)	13MM SOCKET
12	2	M10 FLANGE NUT (BLACK PLATED S/S)	10MM SOCKET
13	2	M10 HEX SOCKET BUTTON HEAD SCREW (BLACK PLATED S/S)	8MM SOCKET
14	8	M8 HEX HEAD BOLT (BLACK ZINC)	6MM SOCKET
15	4	M8 FLANGE NUT (BLACK ZINC)	RATCHET EXT.
16	8	M8 FLAT WASHER (BLACK ZINC)	TORQUE WRENCH
17	4	M8 SPLIT LOCK WASHER (BLACK ZINC)	HAMMER
18	2	M12 FLAT WASHER (YELLOW ZINC)	UTILITY KNIFE
19	2	M12 FLANGE NUT (YELLOW ZINC)	
20	2	M12 LONG HEX BOLT (YELLOW ZINC)	
21	4	OIL COOLER RELOCATOR BRACKET - {USE W/ 2015 TURBO ONLY}	
22	4	M6 CARRIAGE SCREW (BLACK ZINC) - {USE W/ 2015 TURBO ONLY}	
23	4	M6 FLANGE NUT (BLACK ZINC) - {USE W/ 2015 TURBO ONLY}	
24	1	3/4" PLASTIC SPLIT LOOM - {USE W/ TURBO ONLY}	

1. Remove contents from box, verify if all parts listed are present and free from damage. Carefully read and understand all instructions before attempting installation. **Failure to identify damage before installation could lead to a rejection of any claim.**

Note: Anti-seize lubricant must be used on all stainless fasteners to prevent galling.

- Remove the entire front grille and fascia (referred to as front clip) from the front of the vehicle. There are a number of plastic fasteners and metal screws holding it on. Care should be taken not to damage the clip as it is removed. Refer to Figures 1-3.
- If the vehicle has excess material hanging off the lower edge of the bumper channel it must be trimmed in the area shown in (Figure 4) with a grinder or saw in order to allow the brackets to fit. Alternatively a hammer can be used to flatten the edge flush. Refer to Figure 4.
- For 2015 Turbo equipped vehicles only:** The oil cooler must be relocated vertically in order to allow the Push Bumper mounting brackets to fit. Remove the factory hardware attaching the oil cooler to the vehicle. Re-use this hardware to attach the relocater brackets to the vehicle. Use the supplied M6 carriage screws and flange nuts to re-attach the oil cooler to the relocater brackets. Use the supplied split loom to protect the oil line from chafing. Refer to Figures 5 & 6.
- For 2016 + Turbo equipped vehicles only:** The oil cooler does not need to be relocated, use split loom (Item 24) to prevent oil line chafing. Refer to Figure 6.



Westin Automotive Products, Inc.
320 Covina Blvd
San Dimas, Ca. 91773

Thank you for choosing Westin products
for additional installation assistance please call
Customer Service (800) 793-7846
www.westinautomotive.com

Loosen all fasteners and re-
move plastic radiator cover.

Fig. 1

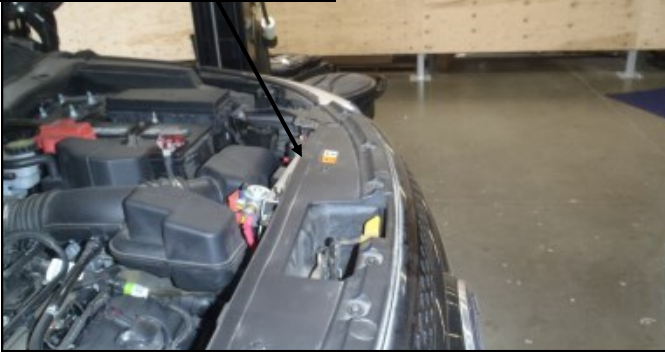
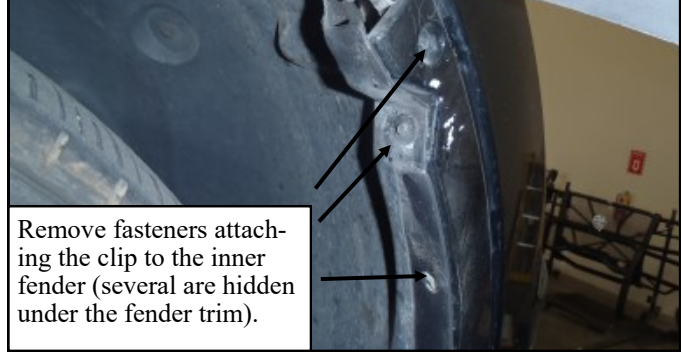

Fig. 2



Remove fasteners attach-
ing the clip to the inner
fender (several are hidden
under the fender trim).

Fig. 3



Remove fasteners attaching clip to lower splash shields, then
carefully pull the front clip off of the vehicle and set aside.

Fig. 4

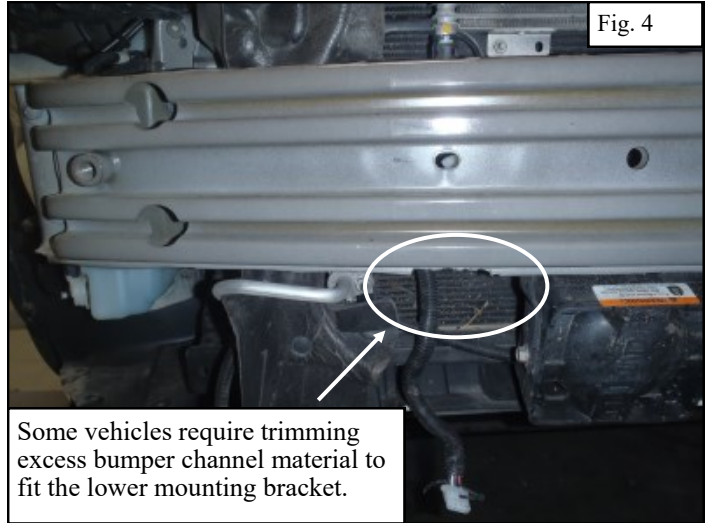

Some vehicles require trimming
excess bumper channel material to
fit the lower mounting bracket.

Fig. 5

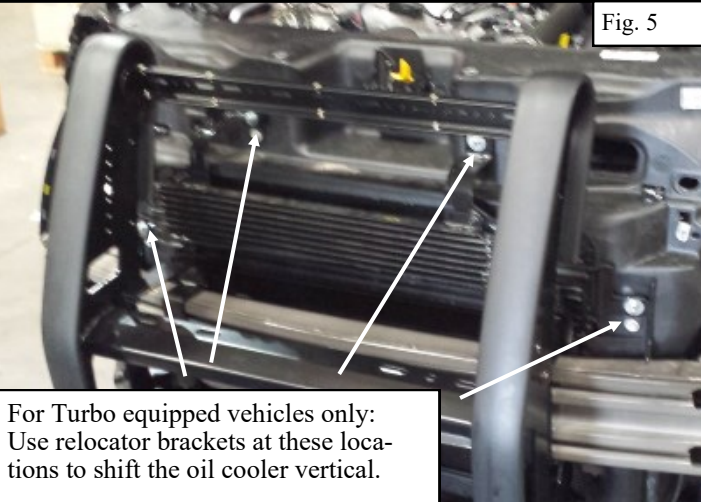

For Turbo equipped vehicles only:
Use relocator brackets at these loca-
tions to shift the oil cooler vertical.

Fig. 6

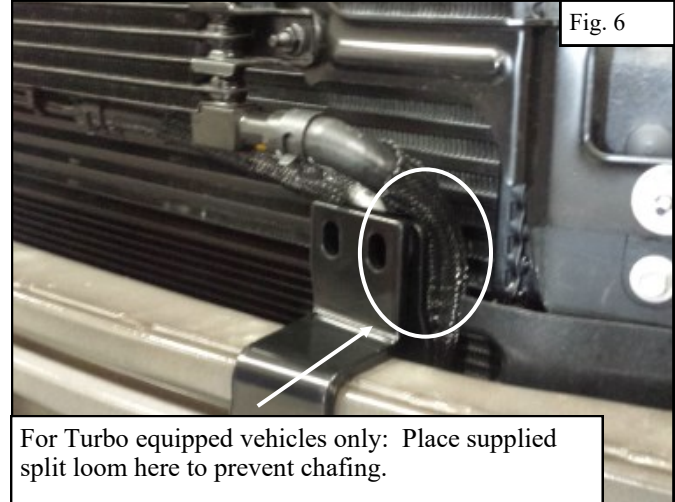

For Turbo equipped vehicles only: Place supplied
split loom here to prevent chafing.

6. Loosely install the mounting brackets, clamp and upper brackets to the exposed bumper bar as shown in (Figure 7). The long M12 bolts go all the way through the bumper channel. The M8 hardware is used to secure the clamp bracket and upper bracket to the mounting bracket.
7. With the front clip still removed from the vehicle, hold the Push Bar up to the brackets and adjust them so that they are centered and will allow the Push Bar to fit over them loosely. Once satisfied with the bracket positioning tighten the long M12 bolts (40-45) ft-lbs. and the lower M8 hardware (24-28) ft-lbs. This ensures that the brackets are located properly. Note: The Upper Support brackets need to stay a little loose in order to allow the clip to fit back over them.



Westin Automotive Products, Inc.
320 Covina Blvd
San Dimas, Ca. 91773

Thank you for choosing Westin products
for additional installation assistance please call
Customer Service (800) 793-7846
www.westinautomotive.com

8. Test fit the vehicle's front clip (the upper support brackets may need to be pushed slightly inboard in order to allow the clip to slip over them). There is a plastic crash channel inside the clip that will interfere with the brackets. Trim the crash channel as necessary in order to re-install the front clip (removing it from the front clip makes trimming easier). Additionally there is a lower grille in the clip that will interfere with the lower mounting brackets; either remove it or trim it as necessary. Refer to Figure 9.
9. Re-install the front clip in reverse order that it was removed. Re-install the plastic radiator cover.
10. Loosely install the Push Bar to the Lower Brackets using the black M12 hardware and to the Upper Support Brackets using the black M10 hardware. Note: If lights are to be installed it is best to install them on the Push Bar prior to bolting the Push Bar to the vehicle.
11. Align and adjust the Push Bar as necessary. Tighten all remaining fasteners (including the M8 hardware which is accessible using a long extension as shown in Figure 10 & Figure 11); M12 to 50-55 ft-lbs., M10 to 30-35 ft-lbs., M8 to 24-28 ft-lbs. and M6 to 7-8 ft-lbs.

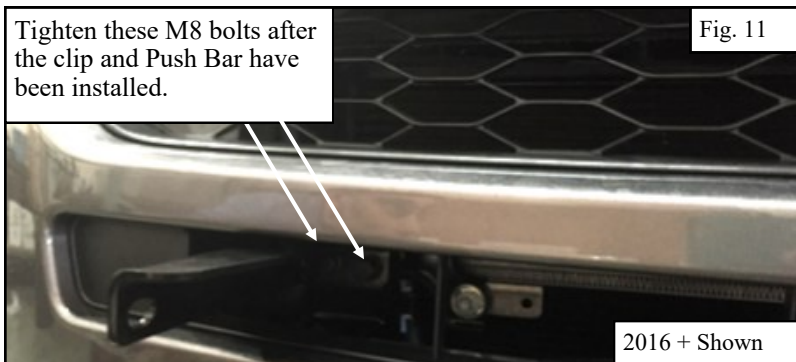
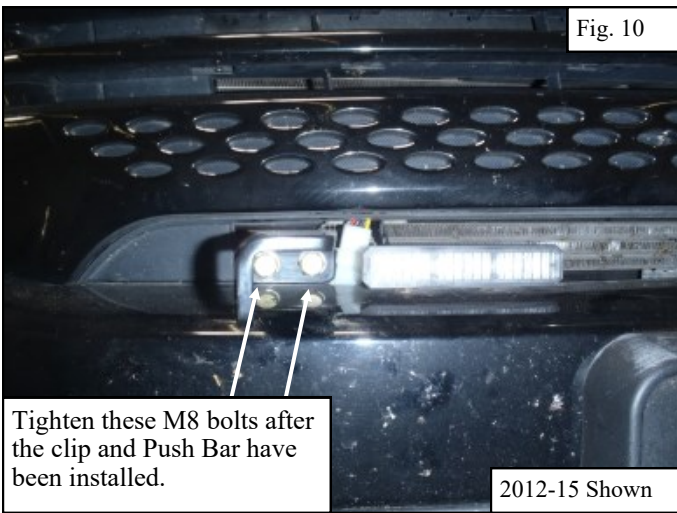
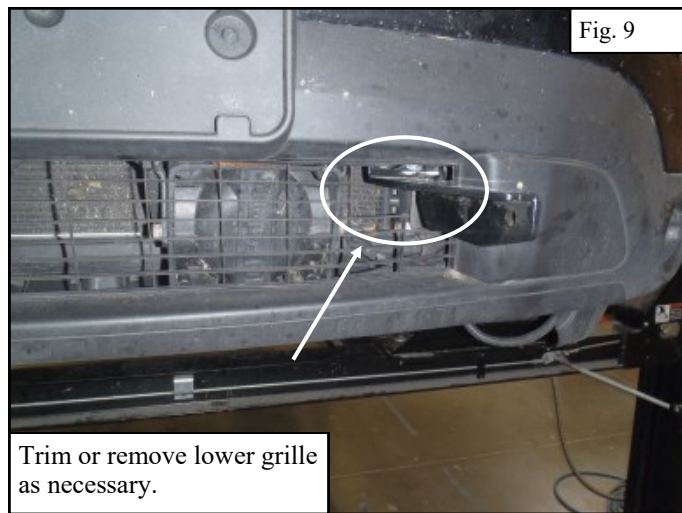
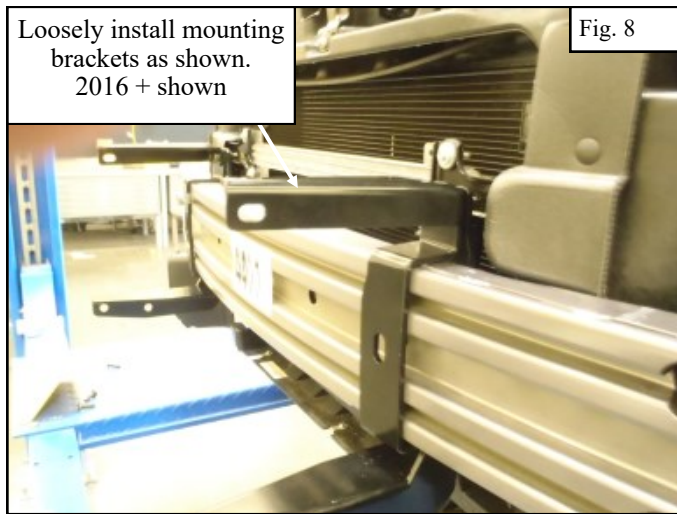
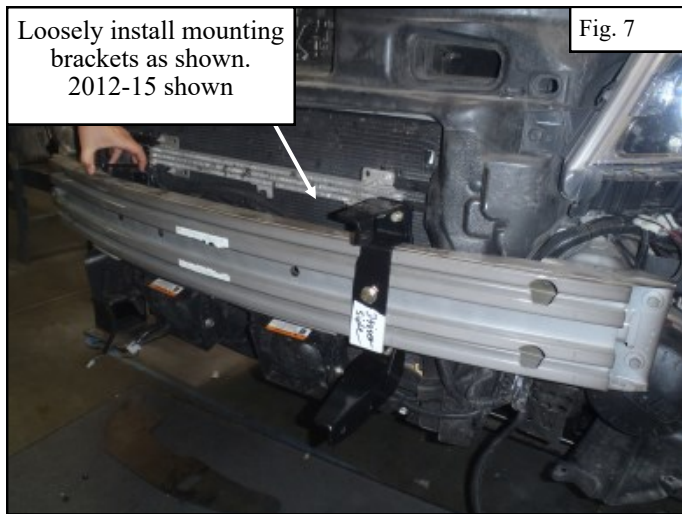

Westin Automotive Products, Inc.
320 Covina Blvd
San Dimas, Ca. 91773

Thank you for choosing Westin products
for additional installation assistance please call
Customer Service (800) 793-7846
www.westinautomotive.com



CARE INSTRUCTIONS:

- REGULAR WAXING IS RECOMMENDED. DO NOT USE ANY TYPE OF POLISH OR WAX THAT MAY CONTAIN ABRASIVES.
- STAINLESS STEEL PRODUCTS CAN BE CLEANED WITH MILD SOAP AND WATER. STAINLESS STEEL POLISH SHOULD BE USED TO POLISH SMALL SCRATCHES.
- GLOSS BLACK FINISHES SHOULD BE CLEANED WITH MILD SOAP AND WATER.



Westin Automotive Products, Inc.
320 Covina Blvd
San Dimas, Ca. 91773

Thank you for choosing Westin products
for additional installation assistance please call
Customer Service (800) 793-7846
www.westinautomotive.com

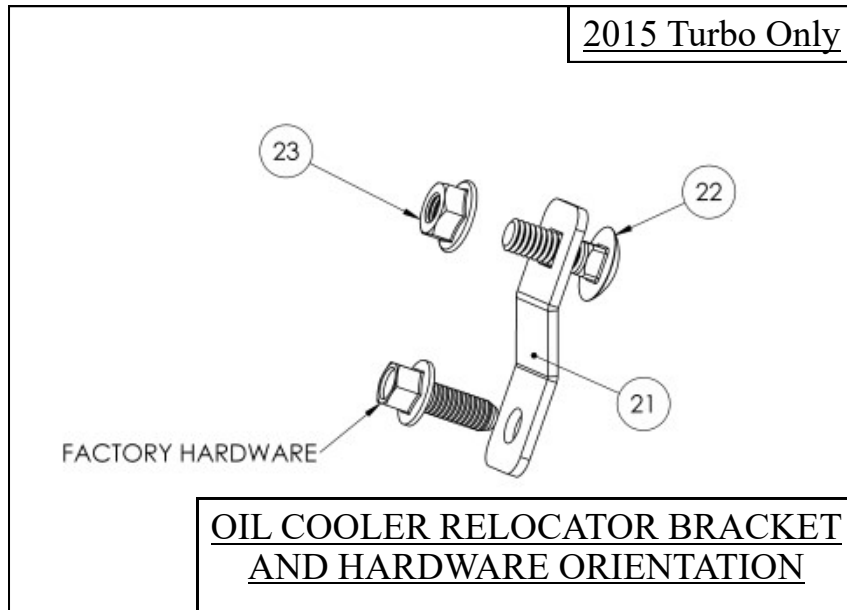
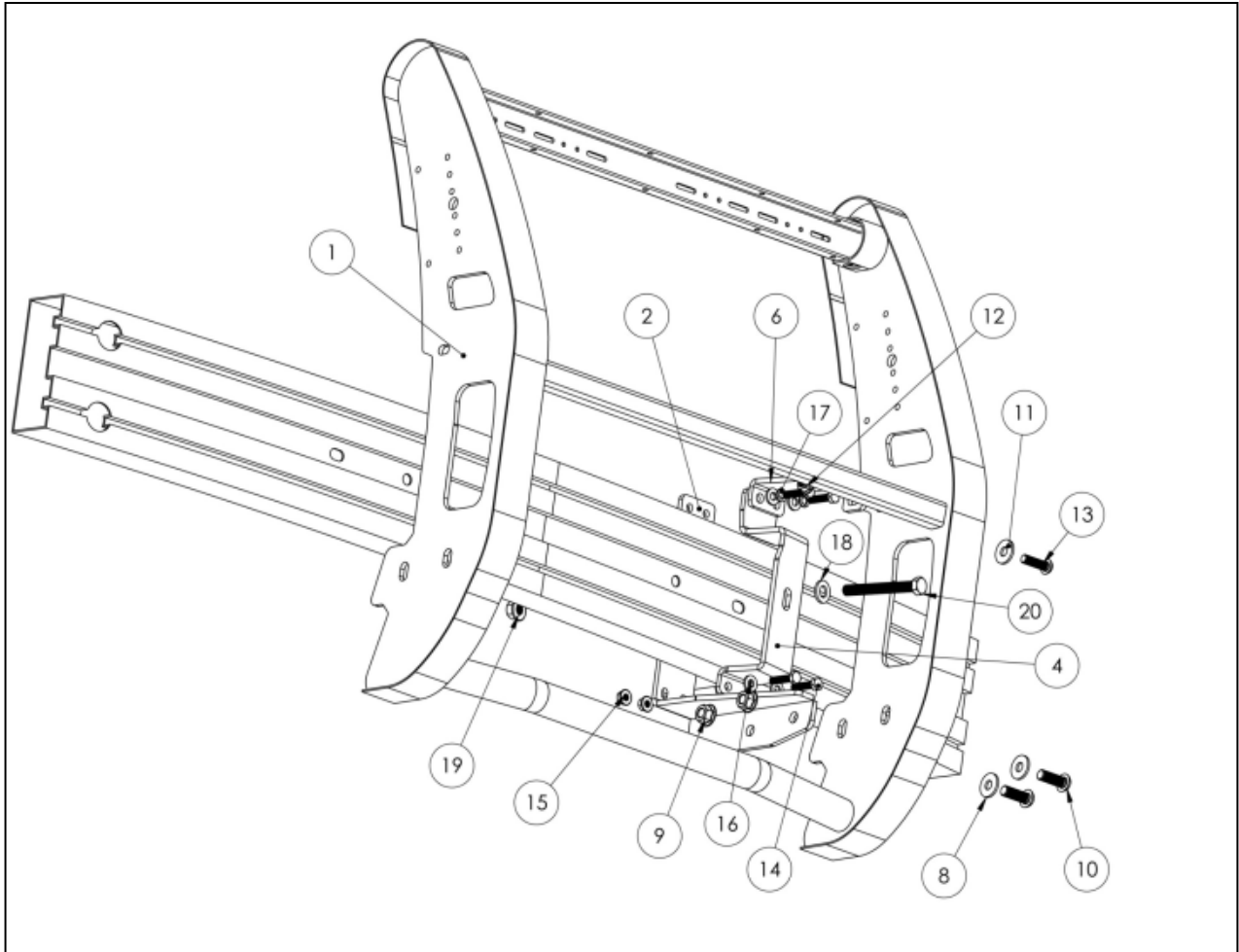

Westin Automotive Products, Inc.
320 Covina Blvd
San Dimas, Ca. 91773

Thank you for choosing Westin products
for additional installation assistance please call
Customer Service (800) 793-7846
www.westinautomotive.com



WARNING



Failure to follow these instructions could lead to death, personal injury, and / or property damage.

Failure to follow these instructions could lead to death, personal injury, and / or property damage.

FASTENERS:

All Westin supplied fasteners must be utilized and installed in accordance with the installation instructions and apply torque to the specifications as defined. **DOUBLE CHECK ALL FASTENERS BEFORE INITIAL USE, AND PERIODICALLY IN THE FUTURE TO ENSURE PROPER FUNCTION AND SAFETY.**

DRILLING:

Most Westin products do not require drilling for installation. If drilling is defined as required, use caution when drilling a vehicle. **FAILURE TO REVIEW AN AREA TO BE DRILLED MAY RESULT IN PERSONAL INJURY AND/OR INJURY TO OTHERS AS WELL AS VEHICLE DAMAGE.**

EYE PROTECTION:

ALWAYS WEAR SAFETY GLASSES OR GOGGLES DURING THE INSTALLATION PROCESS TO AVOID PERSONAL INJURY.

MAXIMUM TOWING/CARRYING CAPACITY: (if applicable)

The Westin Receiver Hitches will have a visible tow rating label affixed directly on the product. User should never exceed the vehicle manufacturers maximum tow and weight rating regardless of the capacity of the hitch. **FAILURE TO FOLLOW THESE GUIDELINES WILL VOID THE WESTIN WARRANTY AND MAY RESULT IN PERSONAL INJURY AND/OR INJURY TO OTHERS AS WELL AS VEHICLE DAMAGE.**

FOR CALIFORNIA RESIDENTS ONLY-PROP 65 WARNING:

Some products may contain chemicals such as DEHP, which can cause cancer, birth defects or other reproductive harm. For more info go to www.p65warnings.ca.gov



Westin Automotive Products, Inc.
320 Covina Blvd
San Dimas, Ca. 91773