

# INSTALLATION INSTRUCTIONS

## DEFENDER SINGLE CELL PARTITION

APPLICATION:

2023-2025 SILVERADO PPV

PART NUMBER:

35-222135

35-2221352



CONTENT			
ITEM	QUANTITY	DESCRIPTION	TOOLS NEEDED
1	1	FRONT PASSENGER PARTITION	10MM SOCKET
2	1	PASSENGER FEET POCKET	10MM WRENCH
3	1	UPPER MOUNTING PASSENGER BRACKET	13MM SOCKET
4	1	MOUNTING PASSENGER BRACKET	13MM WRENCH
5	1	PASSENGER STRAP	16MM SOCKET
6	1	FILLER PLATE	16MM WRENCH
7	1	AIR BAG PLATE	7/16" SOCKET
8	1	CARRIAGE BOLT PLATE	RATCHET
9	1	POLYCARBONATE PASSENGER AIR BAG RELIEF	TORQUE WRENCH
10	1	POLYCARBONATE SINGLE CELL WINDOW	4MM ALLEN WRENCH
11	1	UPPER WINDOW FRAME	5MM ALLEN WRENCH
12	1	LOWER WINDOW FRAME	PHILLIPS SCREWDRIVER
13	1	FRONT WINDOW FRAME	
14	1	REAR FRAME PLATE	3/8" drill stopper
15	2	REAR BACKING PLATE	3/8" drill bit
16	1	LINK BRACKET	MASKING TAPE
17	1	RIV NUT TOOL (35-222135 only)	
18	1	FRONT SEAT BRACKET (35-222135 only)	
19	1	REAR SEAT BRACKET (35-222135 only)	
20	22	1/4"-20 X 0.75" CARRIAGE BOLT GR5	
21	32	1/4" X 0.625" Dim. X 0.6 THICK FLAT WASHER	
22	32	1/4" INTERNAL TOOTH WASHER	
23	32	1/4"-20 A-CORN NUT	
24	9	1/4"-20 X 0.625" CARRIAGE BOLT GR 5	
25	1	1/4"-20 X 1.00" CARRIAGE BOLT GR 5	
26	2	M8—1.25 X 25 MM HEX HEAD SCREW CLASS 8.8	
27	4	M8 X 16MM OD FLAT WASHER	
28	4	M8 SPLIT LOCK WASHER	
29	2	M61.0 X 25MM BUTTON HEAD SCREW CLASS 10.9	
30	6	M6 -1.0 20 MM BUTTON HEAD CAP SCREW CLASS 10.9	







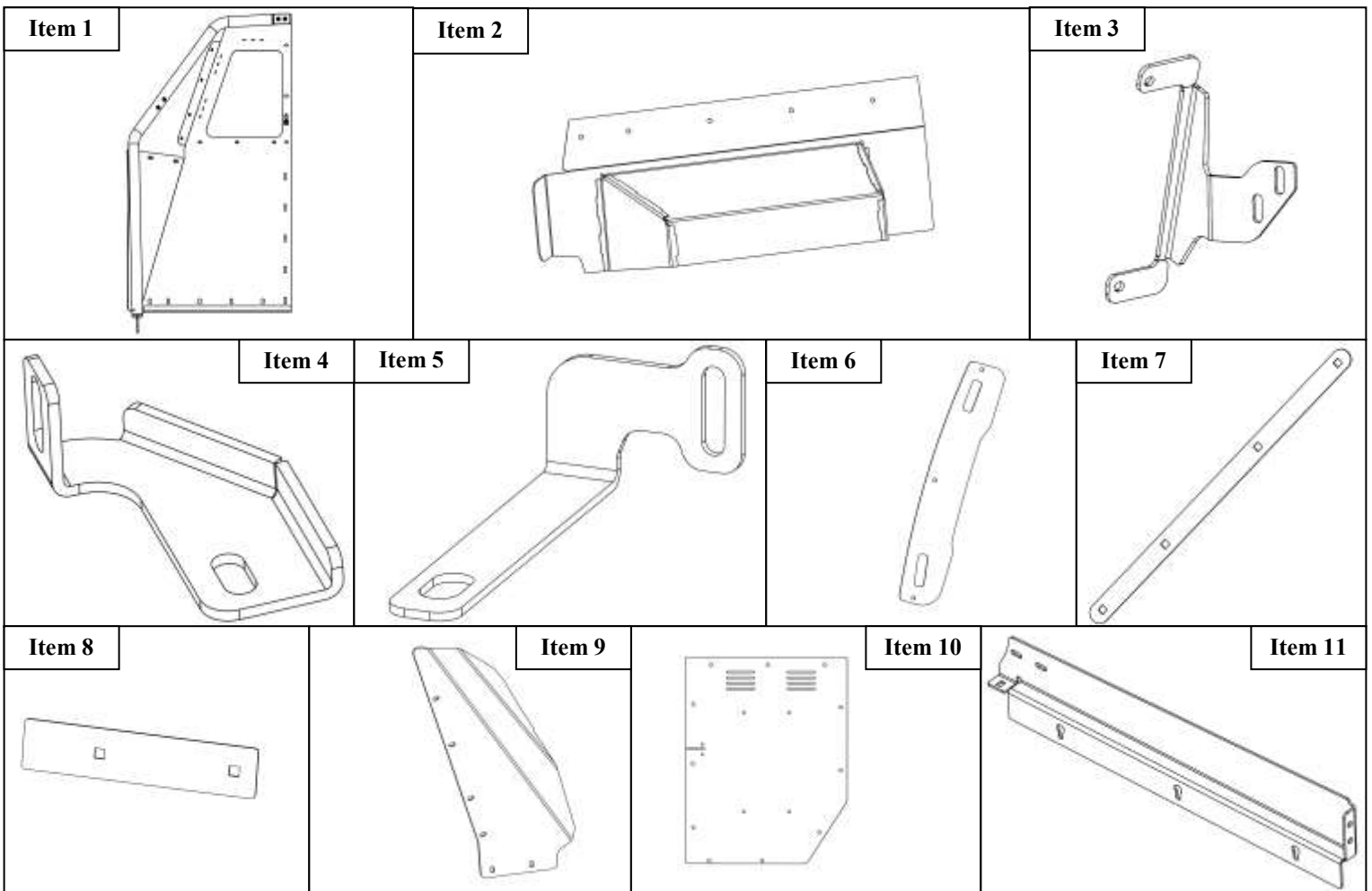

**ANTI-SEIZE LUBRICANT MUST BE USED ON ALL STAINLESS STEEL FASTENERS TO PREVENT THREAD DAMAGE AND GALLING**

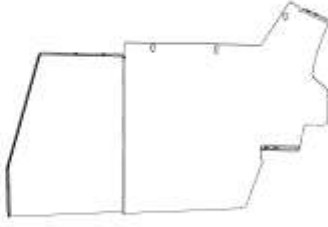
## CONTENT

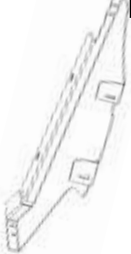
ITEM	QUANTITY	DESCRIPTION	TOOLS NEEDED
31	6	M6—1.0 X 15 MM BUTTON HEAD CAP SCREW CLASS 10.10	
32	14	M6 SPLIT LOCK WASHER	
33	15	M6 X 22MM OD FLAT WASHER	
34	1	M6—1.0 X 30MM HEX HEAD SCREW	
35	4	M6—1.0 RIV NUT (35-222135 only)	
36	5	M6 FLAT WASHER 18MM OD	
37	2	M8 1.25 X 25 MM BUTTON HEAD CAP SCREW CLASS 10.9	
38	2	M8 X 22 MM OD FLAT WASHER	
39	5	M6—1.0 SERRATED FLANGE NUT	
40	1	M10 1.5 X 25MM SERRATED FLANGE BOLT	
41	1	M10—1.5 SERRATED FLANGE NUT	
42	3	ST4.2 X16 CROSS RECESSED PAN HEAD TAPPING SCREWS	
43	1	REAR SUPPORT BRACKET (35-2221352 only)	

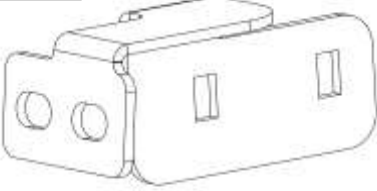
**ANTI-SEIZE LUBRICANT MUST BE USED ON ALL STAINLESS STEEL FASTENERS TO PREVENT THREAD DAMAGE AND GALLING**

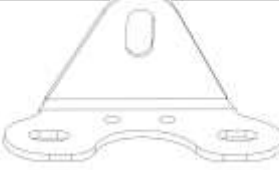

Item 12	35-222135	Item 12	35-2221352	Item 13	
					
Item 14	35-222135	Item 14	35-2221352	Item 15	
					
Item 16		Item 17	35-222135	Item 18	35-222135
					Item 38
					35-2221352
					

### PROCEDURE

1. Remove contents from box, verify if all parts listed are present and free from damage. Carefully read and understand all instructions before attempting installation.  
**Failure to identify damage before installation could lead to a rejection of any claim.**

**NOTE:**

- *Must install Defender Rear Window (P#35-18135) and if needed the Defender Prisoner Seat (P#35-14135) prior to installation.*
- *If 35-12135-D Driver Front Partition needs to be installed, follow steps 8-9 on Install sheets for the 35-12135-D and assemble outside the vehicle the Passenger Side Front Partition (Item 1 on this Install sheets) and Driver Side Front Partition (Item 1 on install sheets for the 35-12135-D) Do not install Window Link Plate item 9 yet from Install Sheet 35-12135-D at this time.*

2. Start the installation by moving the passenger seat to expose the OEM bolts.
3. Remove the rear bolts out of the passenger seat. Locate the Mounting Passenger Bracket (**Item 4**) and slide it under the outer seat rail. Locate the Passenger (**Item 5**) and slide it under the inner seat rails. Loosely install the factory bolts back again. See **Figure 1 & 2** for reference.

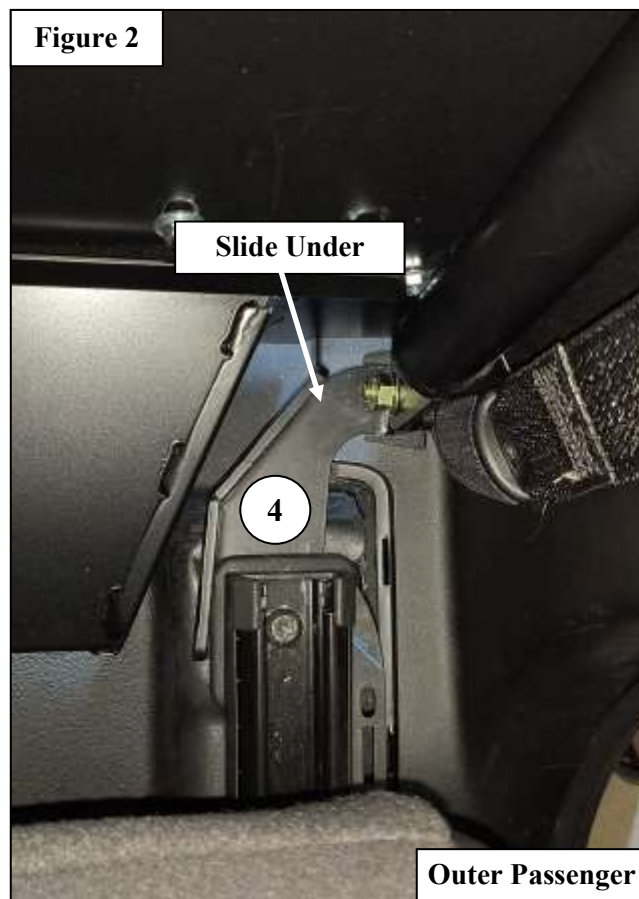

4. Remove the square tab and remove the top screw in the B-Pillar. Using a trim removal tool, remove the plastic paneling on the B-Pillar to access the grab handle. Remove the door rubber seal trim. Remove the factory bolts and grab handle on the passenger side. See **Figure 3 & 4** for reference.
5. Make sure to slide in the Filler Plate (**Item 6**) onto the Upper Mounting Passenger Bracket (**Item 5**). Re-using the factory bolts, assemble the Upper Mounting Passenger Bracket (**Item 5**) to the grab handle bolt holes. Reinstall the factory trim. See **Figure 5 & 6** for reference.
6. Using the supplied Cross Recessed Pan Head Tapping Screw (**Item 42**), assemble the cover plate to the factory trim.

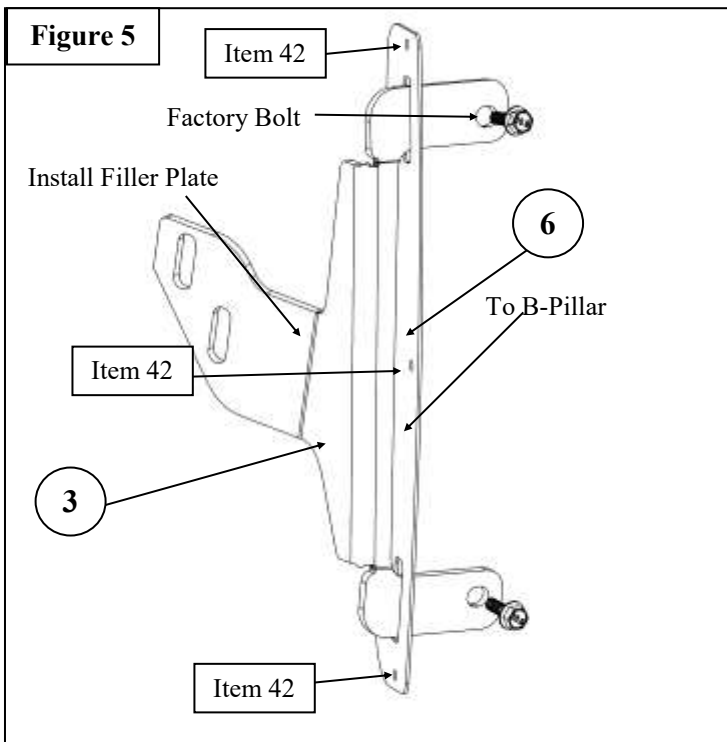
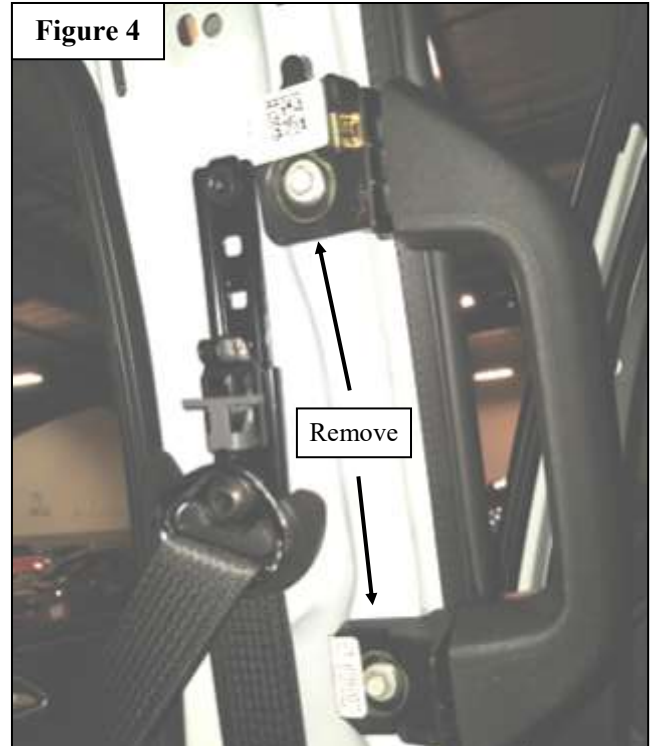
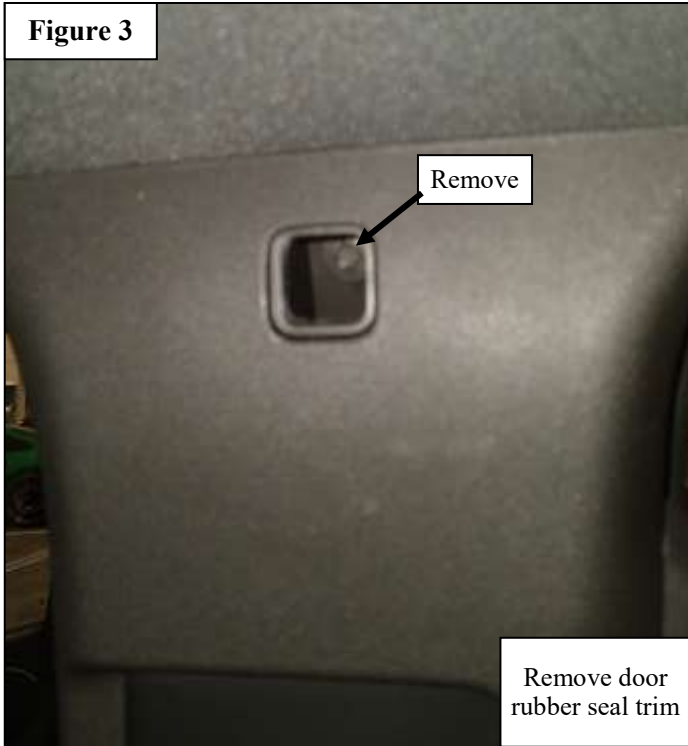

7. Using the hardware provided loosely attach the Front Passenger Partition (**Item 1**) to the Mounting Passenger Bracket (**Item 4**). See **Figure 7** for reference.
8. Using the hardware provided loosely attach the Upper Passenger Mount Bracket (**Item 3**) to the Front Passenger Partition (**Item 1**). See **Figure 8** for reference.

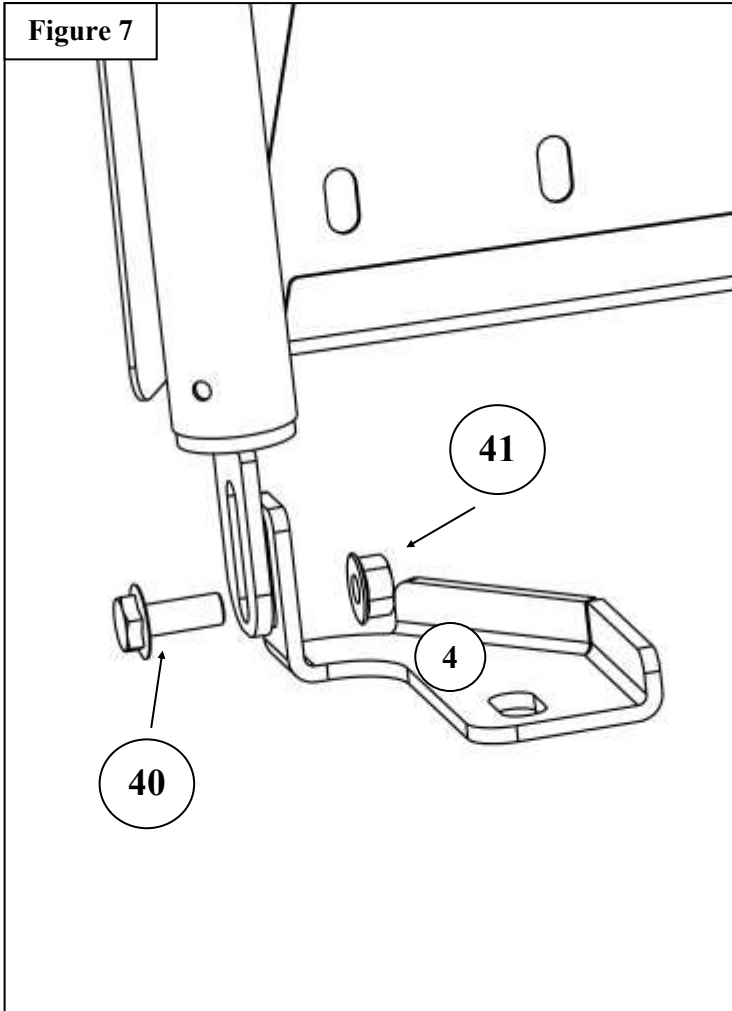

9. Using the provided hardware loosely attach the Passenger Feet Pocket (Item 2) to the Front Passenger Partition (Item 1). See Figure 9 for reference.

10. Locate the Polycarbonate Passenger Air Bag Relief (Item 9), Carriage Bolt Plate (Item 8), and Air Bag Plate (Item 7) to loosely attach it to the Front Passenger Partition (Item 1). See Figure 10 for reference.

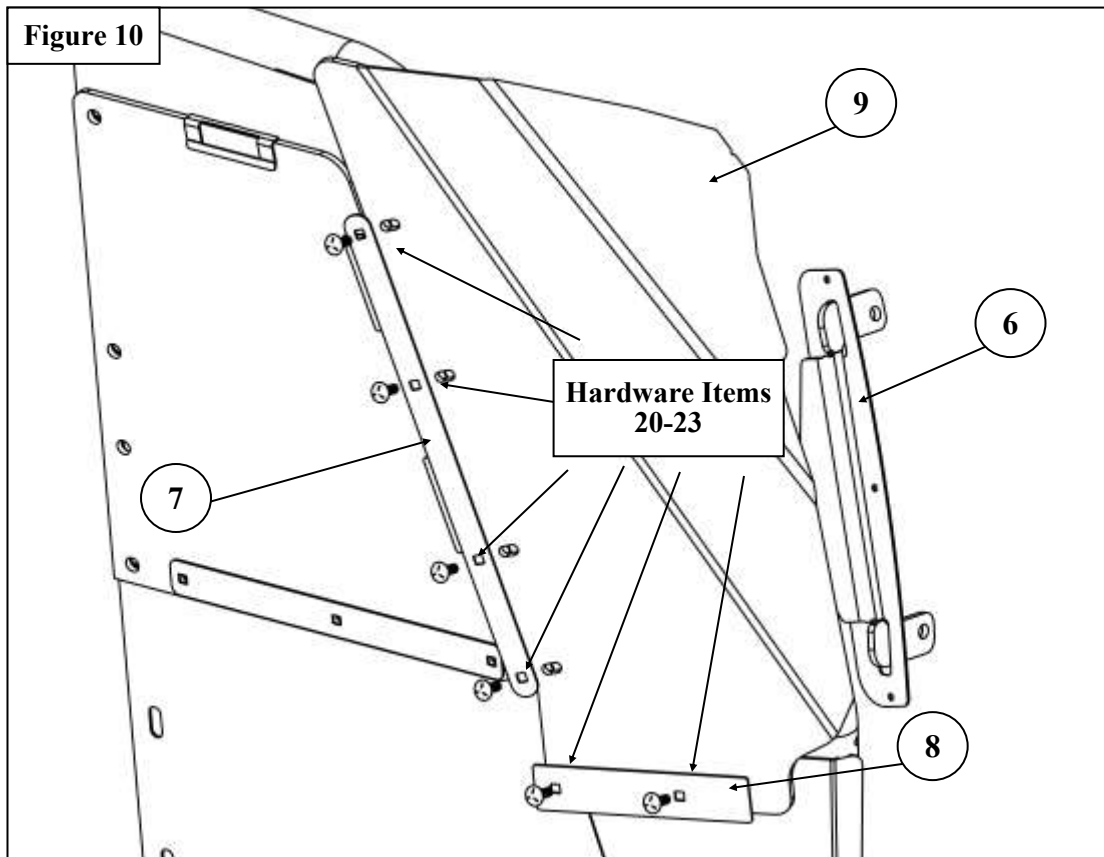
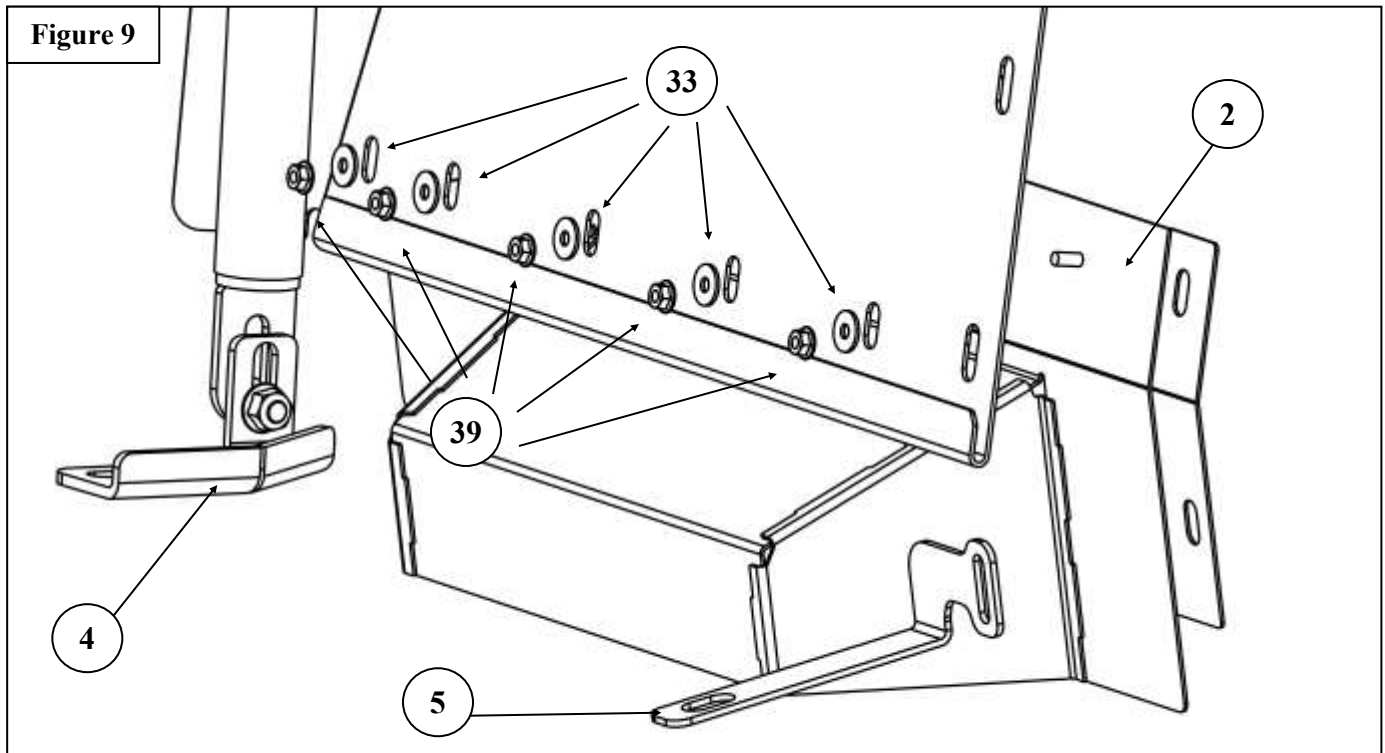

Westin Automotive Products, Inc.  
320 W. Covina Blvd  
San Dimas, Ca. 91773

Thank you for choosing Westin products  
for additional installation assistance please call  
Customer Service (800) 793-7846

[www.westinautomotive.com](http://www.westinautomotive.com)

DATE: 08/27/2024

11. Using the hardware provided, loosely attach the Lower Window Frame (**Item 12**) to the Front Passenger Partition (**Item 1**). See **Figure 11** for reference.
12. Using the hardware provided, loosely attach the Passenger Strap (**Item 5**) to the Front Passenger Partition (**Item 1**) and Lower Window Frame (**Item 12**). See **Figure 11** for reference.

**Note:** If installing PN 35-222135 install prisoner seat first. If prisoner seat is not being used see **Figure 12**.

**Figure 12**

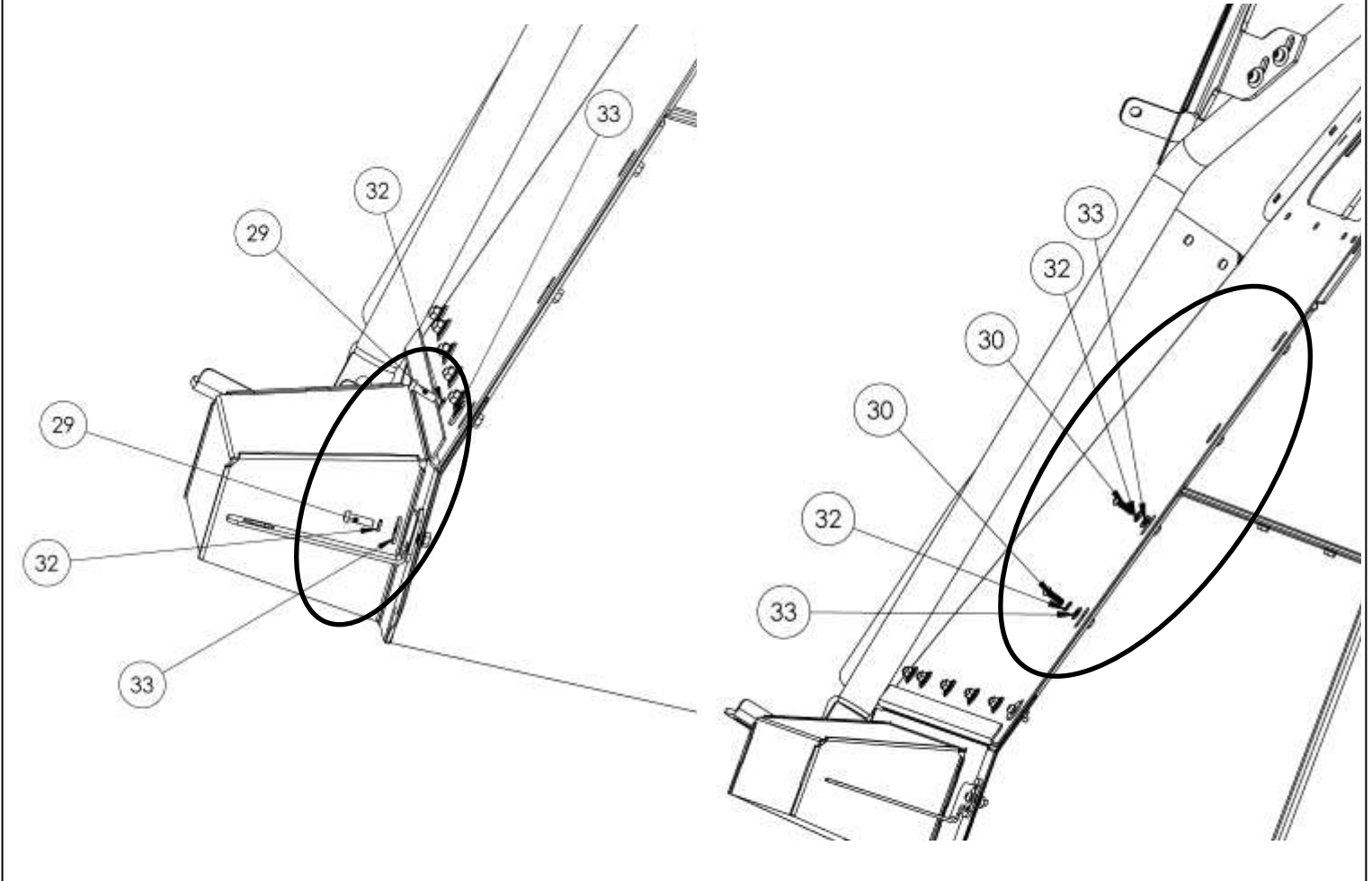



13. Locate the Rear Link Bracket (**Item 20**) and attach it to the Rear Window Frame (**Item 14**). See **Figure 12** for reference.
14. Using the provided hardware, attach the Rear Backing Plate (**Item 15**) and Rear Support Bracket (**Item 16**) to the Defender Rear window (**Part #35-18135**).
15. Using the provided hardware, loosely assemble the Rear Window Frame (**Item 14**) to the Lower Window Frame (**Item 12**).

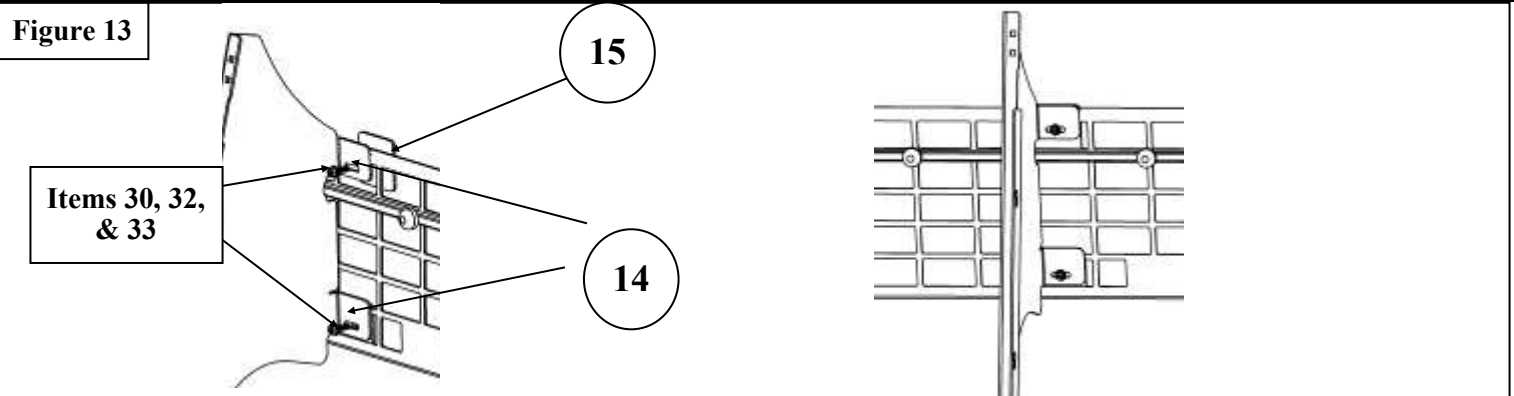

16. Locate and attach the Link Bracket (**Item 17**) and the Upper Window Frame (**Item 11**) using the hardware provided. See **Figure 14** for reference.
17. Loosely assemble the Upper Window Frame (**Item 11**) to the Front Passenger Partition (**Item 1**) and Rear Window Frame (**Item 14**) using the hardware provided. See **Figure 15** for reference.

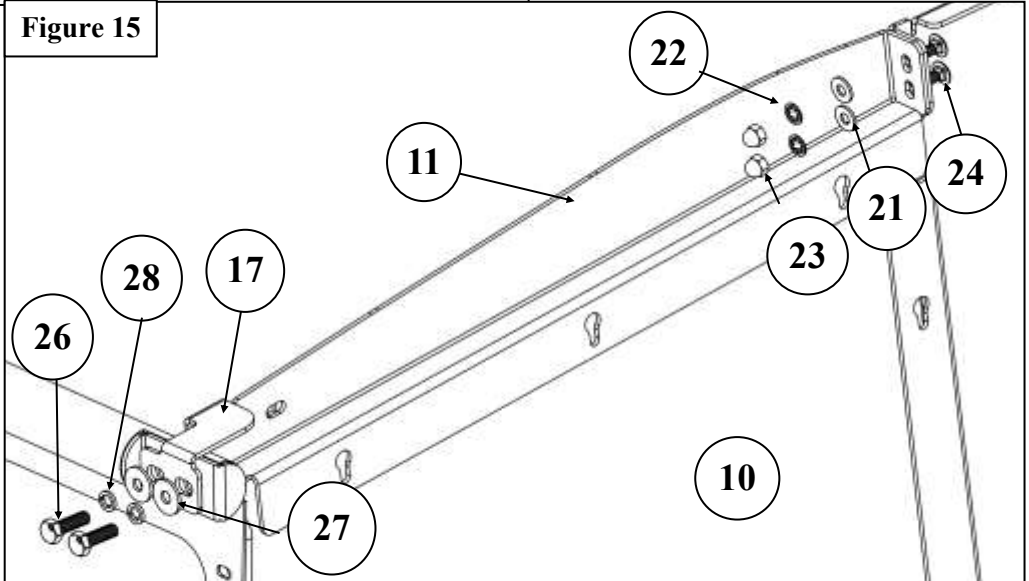
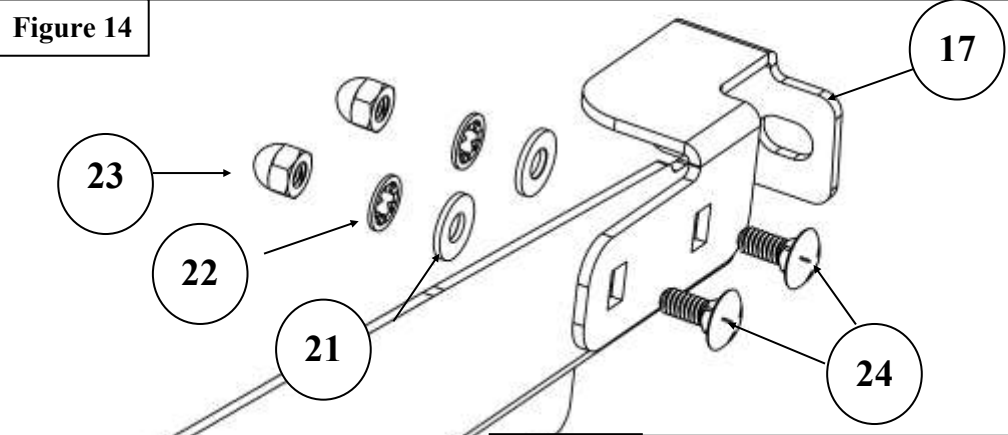

18. Using the hardware provided, locate and align the Front Window Frame (Item 13) with the Upper Window Frame (Item 11), Lower Window Frame (Item 12), and the Front Passenger Partition (Item 1). See Figure 16-18 for reference.

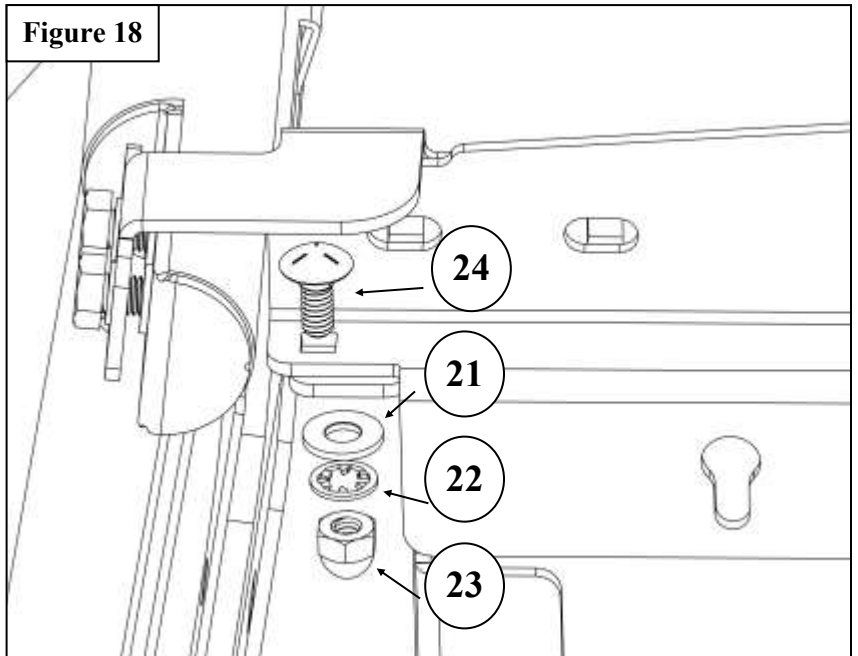
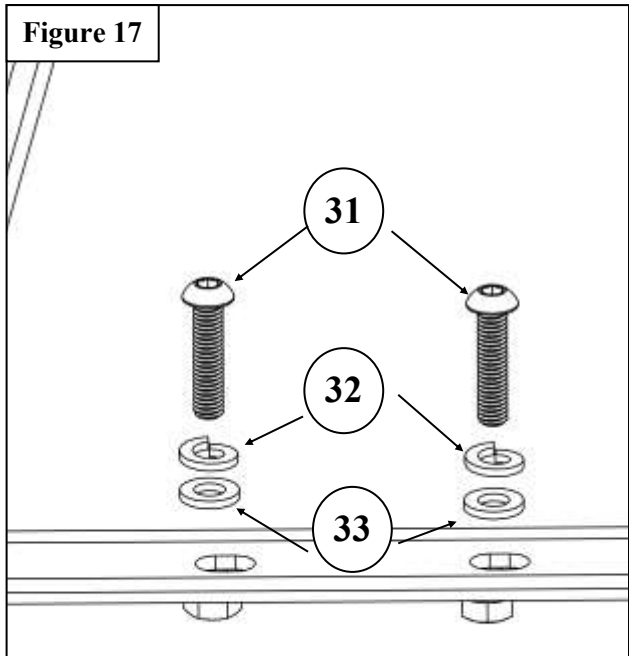
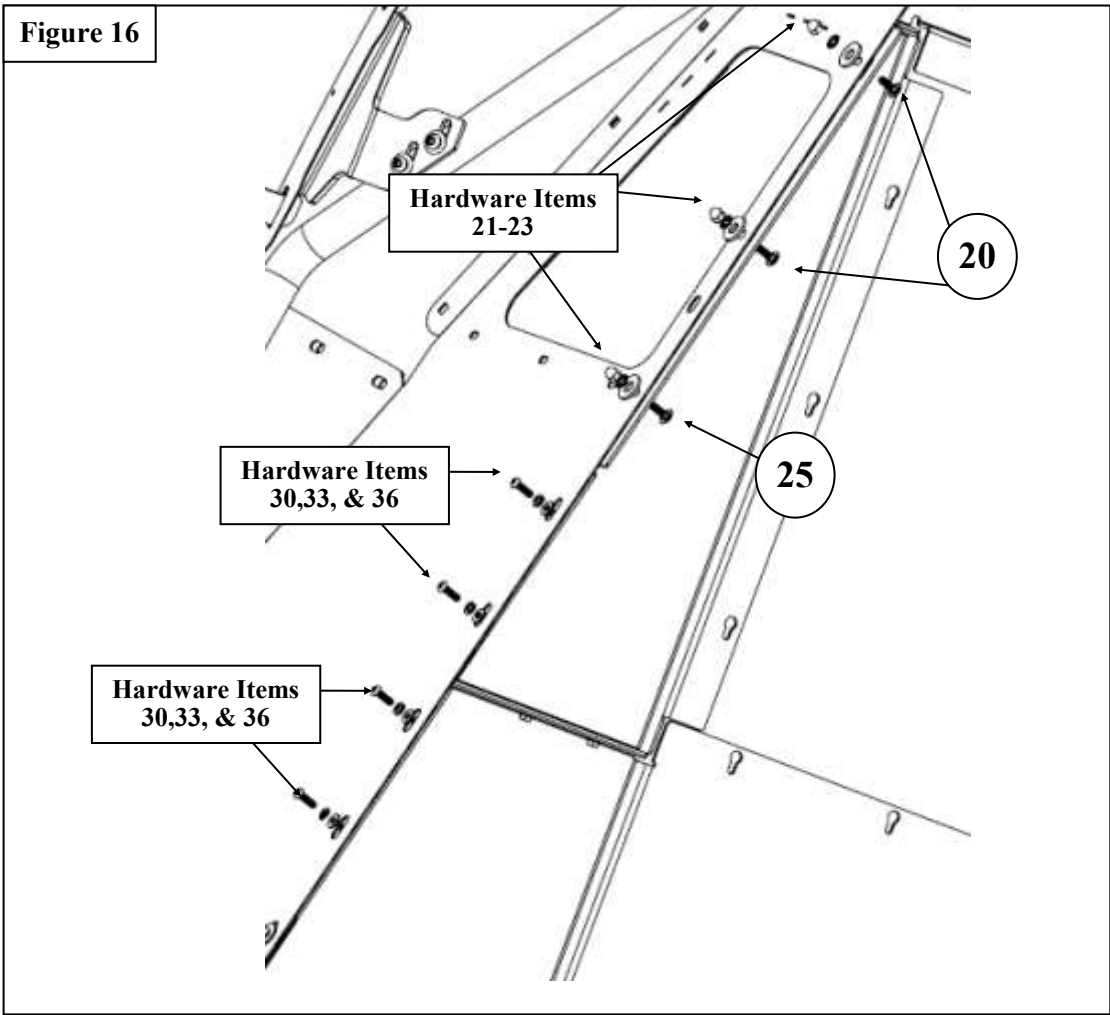

19. If the vehicle has the Prisoner Seat (**Part # 35-14135**) installed align and adjust the Front Seat Bracket (**Item 18**) and Rear Seat Bracket (**Item 19**) as necessary with a mark that would indicate the location of the drilling hole (**Size 3/8"**) on the prisoner seat. See **Figures 19-23** for reference.
20. Use **A drill stopper (not provided)** at **3/8"** from the drill bit's tip and drill 4 holes. See **Figure 19**.  
**\*\*IMPORTANT\*\* Must use the stopper as indicated Or OE SEAT MAY GET DAMAGED**
21. Insert and install 4 Riv nuts using riv nut tool and items 33 & 34 see **Figure 21**.

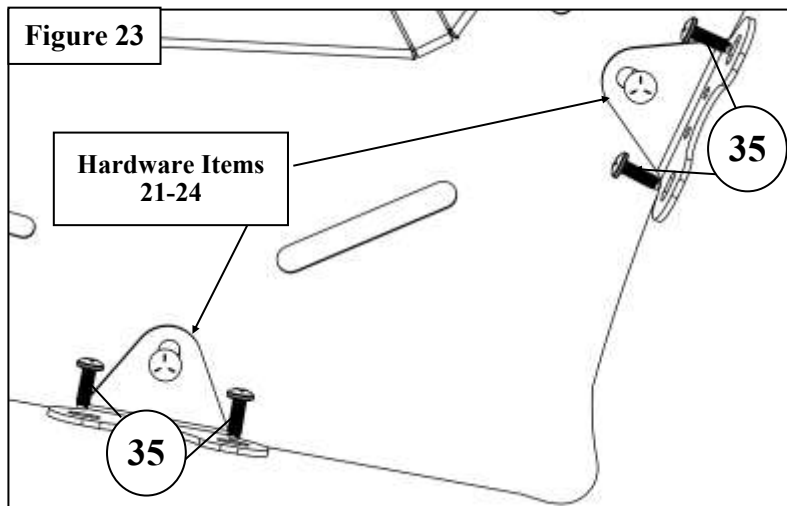
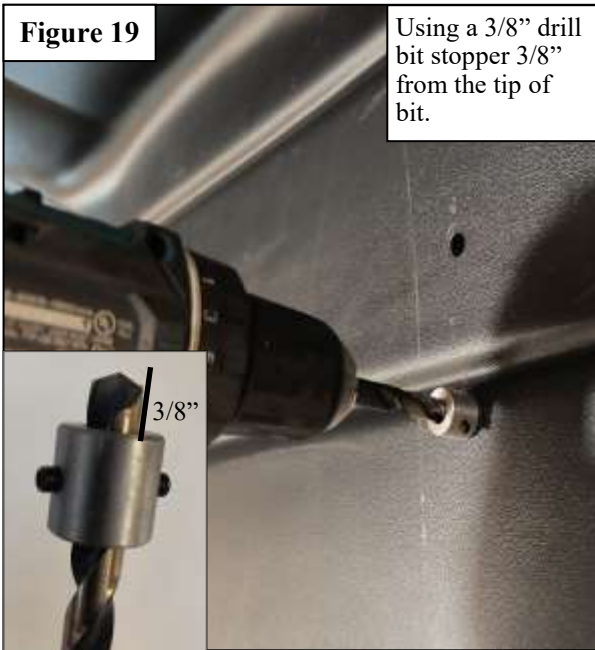



Figure 24

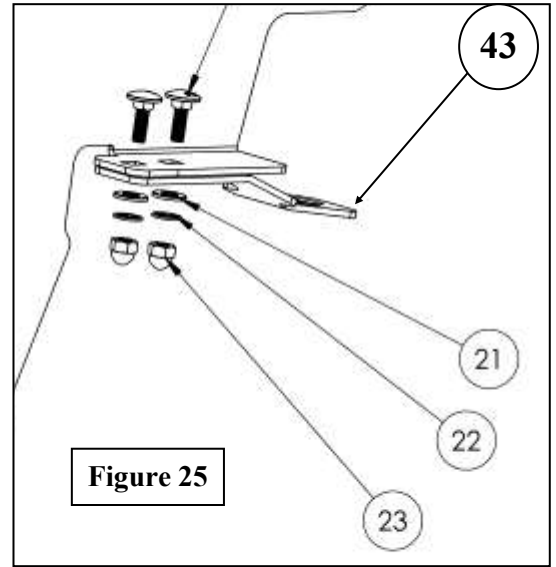

Figure 25

22. **NOTE:** If vehicle does not have the Prisoner Seat (**Part # 35-14135**), the Lower Window Frame (**Item 12**) can slide in between the rear passenger seat and middle seat. Install Lower rear bracket (43) using the seat belt receiver bolt. See **Figure 24 & 25. Page 12**
23. Using the hardware provided, attach the Polycarbonate Single Cell Window (**Item 10**). See **Figure 21 & 22** for reference.
24. Align and adjust the Defender Single Cell Partition. Tighten and torque all hardware as specified: M6 to 8-11 ft-lbs, M8 to 15-18 ft-lbs., and M10 to 35-38 ft-lbs.

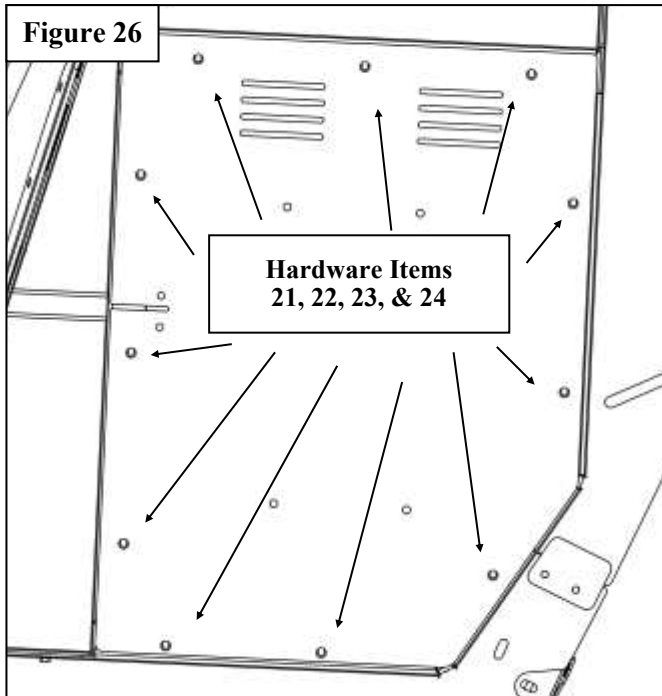

Figure 26

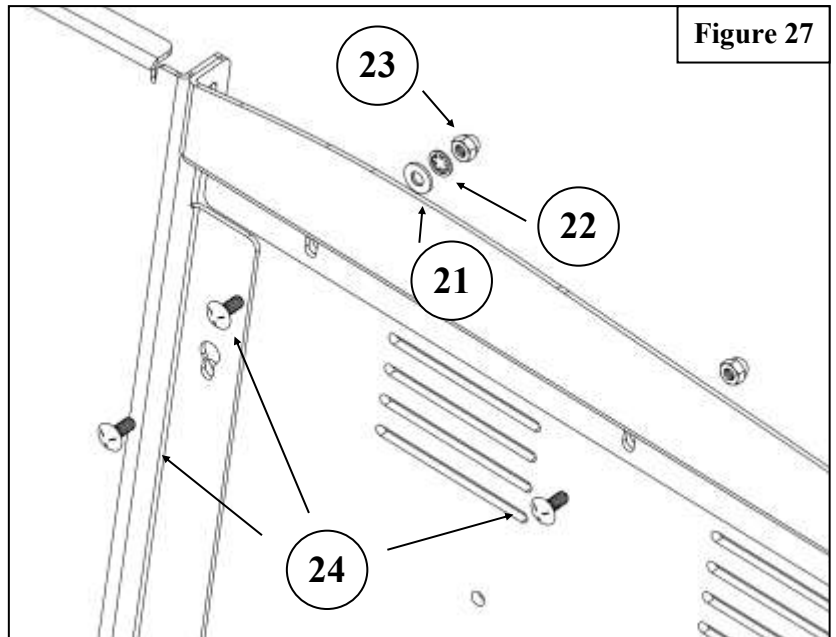

Figure 27

**INSTALLATION COMPLETE**



**CARE INSTRUCTIONS**

- REGULAR WAXING IS RECOMMENDED. DO NOT USE ANY TYPE OF POLISH OR WAX THAT MAY CONTAIN ABRASIVES.
- STAINLESS STEEL PRODUCTS CAN BE CLEANED WITH MILD SOAP AND WATER. STAINLESS STEEL POLISH SHOULD BE USED TO POLISH SMALL SCRATCHES.
- GLOSS BLACK FINISHES SHOULD BE CLEANED WITH MILD SOAP AND WATER.

**WESTIN** Westin Automotive Products, Inc.  
320 W. Covina Blvd  
San Dimas, Ca. 91773

Thank you for choosing Westin products  
for additional installation assistance please call  
Customer Service (800) 793-7846  
[www.westinautomotive.com](http://www.westinautomotive.com)  
DATE: 08/27/2024



## WARNING



Failure to follow these instructions could lead to death, personal injury, and / or property damage.

Failure to follow these instructions could lead to death, personal injury, and / or property damage.

### FASTENERS:

All Westin supplied fasteners must be utilized and installed in accordance with the installation instructions and apply torque to the specifications as defined. **DOUBLE CHECK ALL FASTENERS BEFORE INITIAL USE, AND PERIODICALLY IN THE FUTURE TO ENSURE PROPER FUNCTION AND SAFETY.**

### DRILLING:

Most Westin products do not require drilling for installation. If drilling is defined as required, use caution when drilling a vehicle. **FAILURE TO REVIEW AN AREA TO BE DRILLED MAY RESULT IN PERSONAL INJURY AND/OR INJURY TO OTHERS AS WELL AS VEHICLE DAMAGE.**

### EYE PROTECTION:

**ALWAYS WEAR SAFETY GLASSES OR GOGGLES DURING THE INSTALLATION PROCESS TO AVOID PERSONAL INJURY.**

### MAXIMUM TOWING/CARRYING CAPACITY: (if applicable)

The Westin Receiver Hitches will have a visible tow rating label affixed directly on the product. User should never exceed the vehicle manufacturers maximum tow and weight rating regardless of the capacity of the hitch. **FAILURE TO FOLLOW THESE GUIDELINES WILL VOID THE WESTIN WARRANTY AND MAY RESULT IN PERSONAL INJURY AND/OR INJURY TO OTHERS AS WELL AS VEHICLE DAMAGE.**

### FOR CALIFORNIA RESIDENTS ONLY-PROP 65 WARNING:

Some products may contain chemicals such as DEHP, which can cause cancer, birth defects or other reproductive harm. For more info go to [www.p65warnings.ca.gov](http://www.p65warnings.ca.gov)



Westin Automotive Products, Inc.  
320 W. Covina Blvd  
San Dimas, Ca. 91773