



# INSTALLATION INSTRUCTIONS DEFENDER POLY REAR PARTITION

APPLICATION:  
2021-2023 Dodge Durango  
PART NUMBER:  
35-220752

<b>CONTENT</b>			
<b>ITEM</b>	<b>QUANTITY</b>	<b>DESCRIPTION</b>	<b>TOOLS NEEDED</b>
1	1 & 1	FRAMES LH AND RH	10MM SOCKET
2	1	CENTER FILER PANEL	13MM SOCKET
3	1	DRIVER SIDE FILER PANEL	17MM SOCKET
4	1	PASSENGER SIDE FILER PANEL	RATCHET
5	1	DRIVER SIDE MOUNTING BRACKET	TORQUE WRENCH
6	1	PASSENGER SIDE MOUNTING BRACKET	CUTTING TOOL
7	1	DRIVER SIDE FLOOR STRAP	TRIMMING TOOL
8	1	PASSENGER SIDE FLOOR STRAP	POWER DRILL
9	1	DRIVER SIDE EXTENSION MOUNTING BRACKET	DRILL BITS
10	1	PASSENGER SIDE EXTENSION MOUNTING BRACKET	
11	1	BELT SUPPORT BRACKET	
12	1	CROSS FRAME	
13	40	M6 FLANGE HEX HEAD NUT	
14	40	M6 FLAT WASHER	
15	20	SHORT M8 HEX HEAD BOLT	
16	4	LONG M8 HEX HEAD BOLT	
17	2	M8 SERRATED FLANGE HEX HEAD NUT	
18	24	M8 FLAT WASHER	
19	24	M8 LOCK WASHER	
20	2	M10 HEX HEAD BOLT	
21	6	#8 SELF TAPPING SHEET METAL SCREWS	
22	1	DRIVER SIDE CUTTING TEMPLATE	
23	1	PASSENGER SIDE CUTTING TEMPLATE	
24	8	M6 BOTTOM HEAD BOLT LONG	
25	1	COVER PLATE	
26	2	M6 BOLT PLATE	
27	2	M6 POLY RETAINER	
28	1	FISHWIRE	
29	1	UPPER STRAP DRIVER	
30	1	UPPER STRAP PASSENGER	
31	6	M12 FLAT WASHER	
32	2	M12 FLANGE HEX NUT	
33	2	M12 HEX HEAD BOLT	
34	1	SUPPORT BAR	
35	26	M6 BOTTOM HEAD BOLT SHORT	
36	1	POLYWINDOW	

**ANTI-SEIZE LUBRICANT MUST BE USED ON ALL STAINLESS STEEL FASTENERS TO PREVENT THREAD DAMAGE AND GALLING**

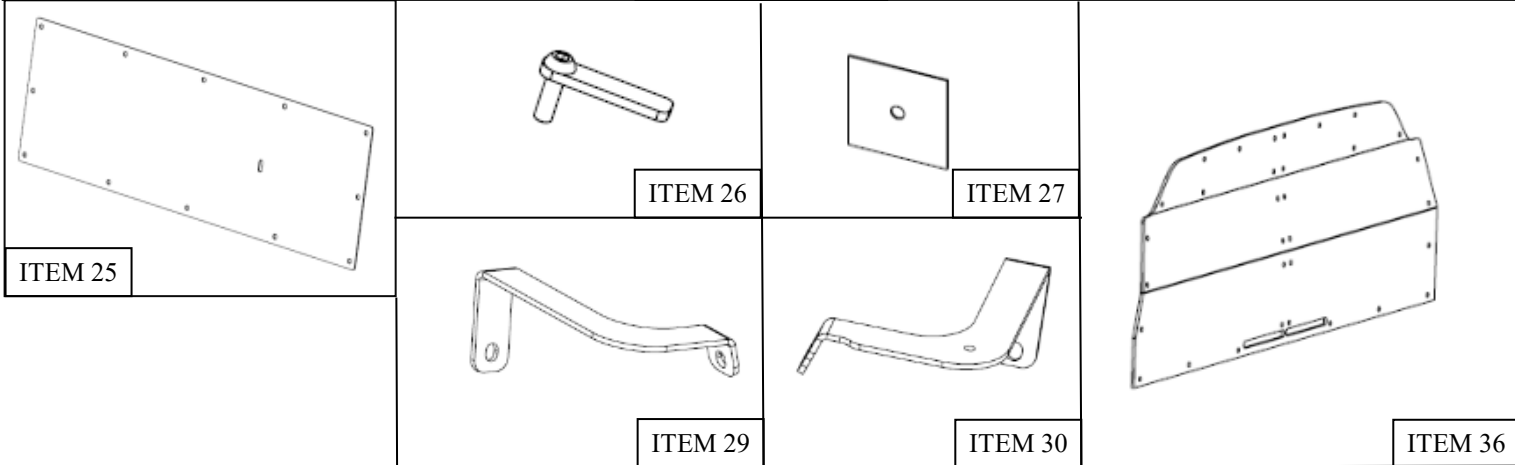
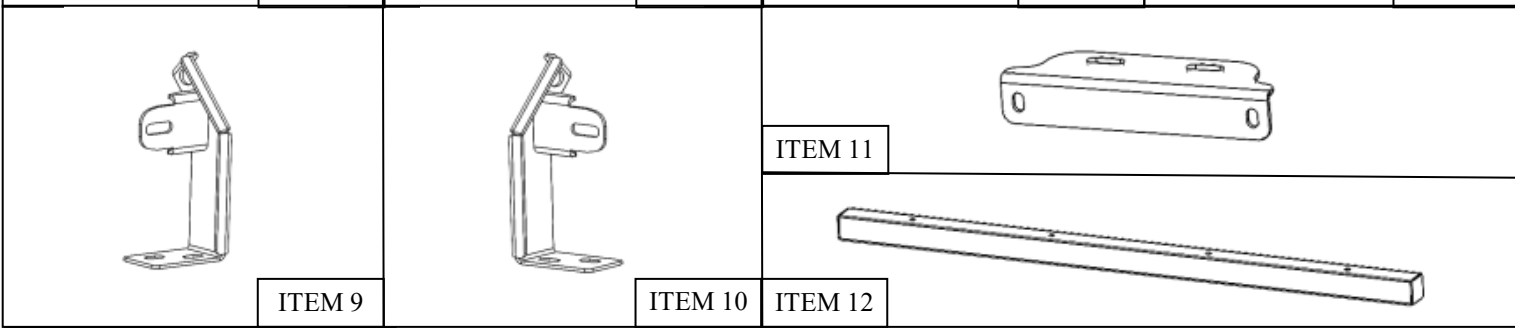
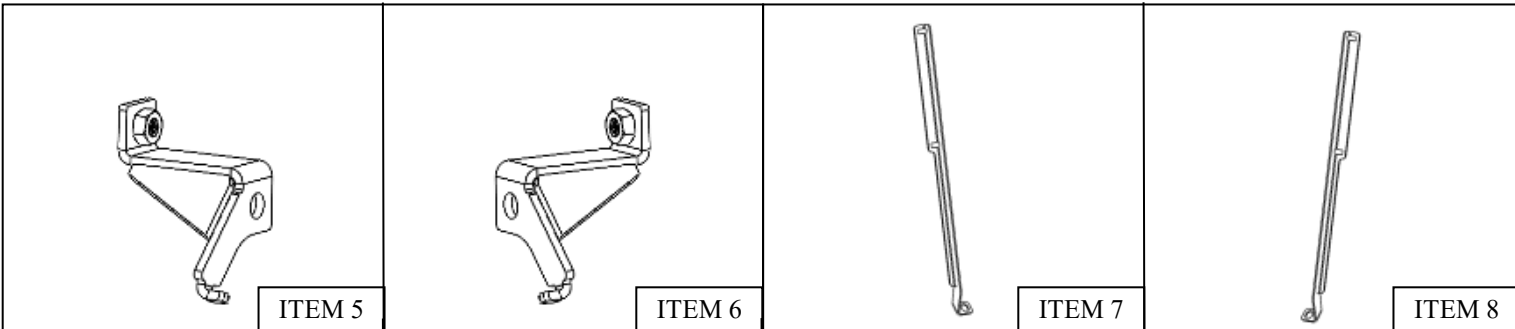
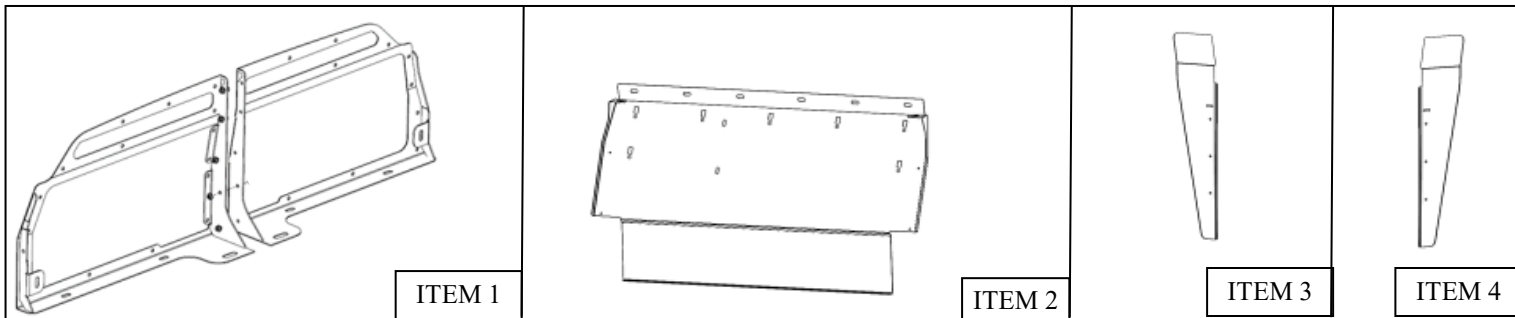

**PROCEDURE**

1. Remove contents from box, verify if all parts listed are present and free from damage. Carefully read and understand all instructions before attempting installation. **Failure to identify damage before installation could lead to a rejection of any claim.**
2. Find the release two seat cable wires on both the rear driver and passenger side of the vehicle and flip the rear seats toward the front to allow room for easy access. See **Figure 1 & 2** for reference.



Figure 1

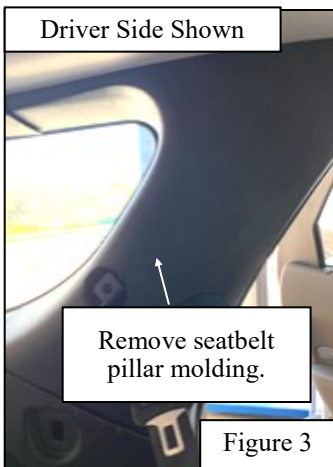

Driver Side Shown

Remove seatbelt pillar molding.

Figure 3



Figure 2

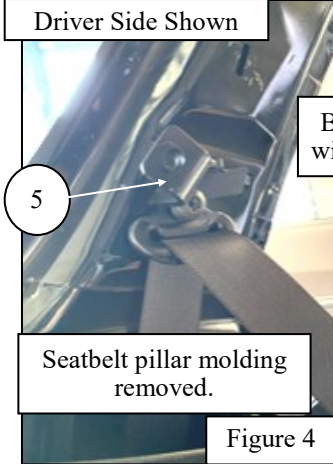

Driver Side Shown

5

Bracket is mounted with OEM hardware.

Seatbelt pillar molding removed.

Figure 4

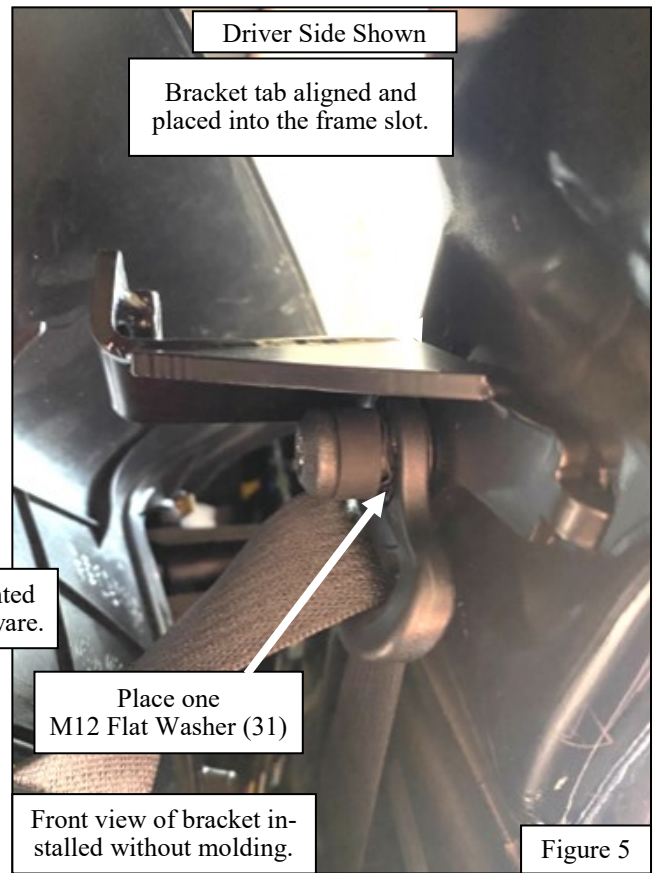

Driver Side Shown

Bracket tab aligned and placed into the frame slot.

Place one M12 Flat Washer (31)

Front view of bracket installed without molding.

Figure 5

3. Remove both the driver seatbelt pillar molding shown in **Figure 3**.
4. Remove the T45 torx head bolt securing the seatbelt to the vehicle pillar. Locate and install the Driver Mounting Bracket (Item 5) at this same location under the seatbelt mount using the a M12 Flat washer (31) and the OEM torx head bolt. Make sure to align the Bracket's tab into the frame slot. Tighten it completely at this time and torque to 35 to 40 ft-lbs. See **Figure 4 & 5** for reference.
5. Using a 5/16" drill bit increases the hole size on both pillars as shown on image below. **Figure 6**.
6. Using the provided M6 Fish wire, carefully, through the square holes place the provided M6 bolt plates (26) into the 5/6" holes. Use the provided poly retainer (27) to hold the bolt plate in place (red arrow). **Figures 7 & 8**.
7. Using M6 flange nuts install the driver and passenger top straps (29, 30) (Bigger strap is passenger) to the pillars. Strap flange must be parallel to the square holes (see image below, red markings). Do not install the frame yet. Tighten nuts and proceed to step 5 on install sheets. Note: Might need to do small trim the pillar molding to clear the strap. **Figure 9**.
8. Reinstall the seatbelt pillar molding.
9. Repeat for passenger side (Item 6).

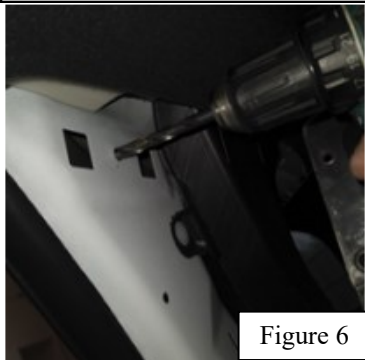

Figure 6

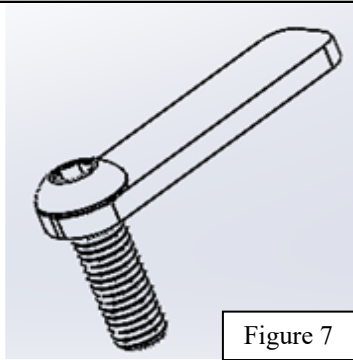

Figure 7

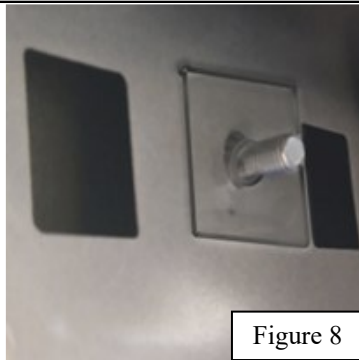

Figure 8

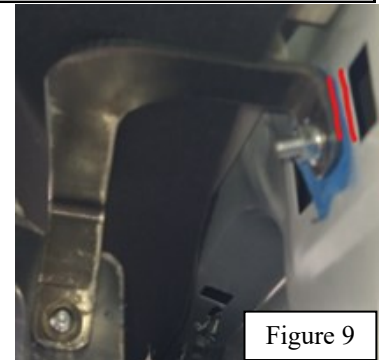

Figure 9

- Using the provided Driver and Passenger Cutting Templates (Items 22 & 23), cut into the seatbelt pillar molding shown in order to create an opening for the Driver and Passenger Mounting Brackets (Items 5 & 6).

**Cutting Instructions using the provided Cutting Templates (Items 22 & 23)**

- Align the template properly and it can be easiest to start by drilling a small pilot hole. See **Figure 7** for reference.
- Using this pilot hole as a reference once it appears to be aligned with the mounting bracket hole, you can use the cutting tool to make the 2 inch diameter hole opening for the mounting bracket. See **Figure 12 & 13** for reference.
- The seatbelt pillar molding may also be removed to drill completely through once you are confident of the hole location.
- On the PASSENGER side, be VERY careful when drilling and cutting because of the AC air dam shown in Figure 10.**

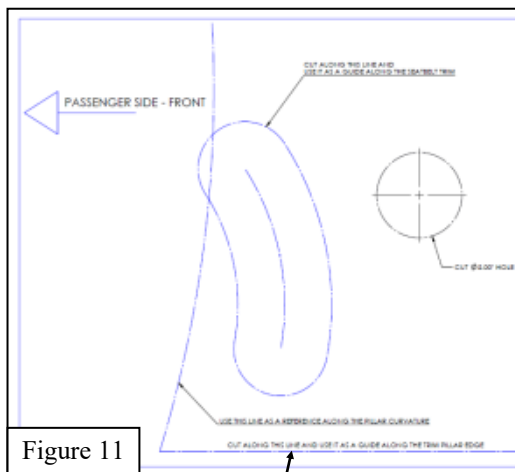
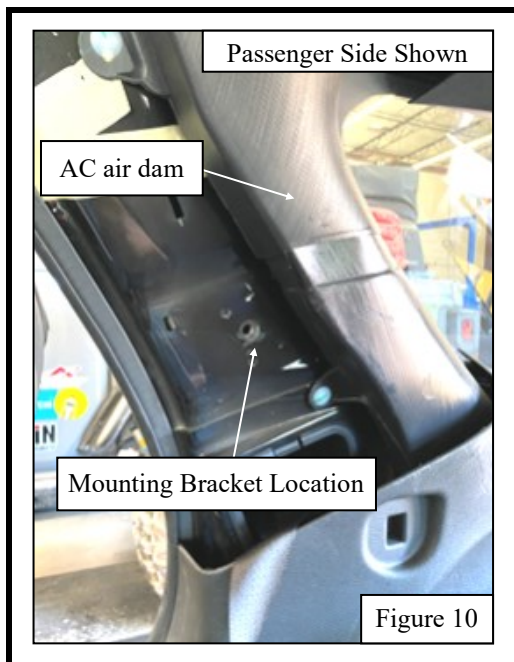

Figure 11

Use this line as a reference for the cutting template. Align the template properly per the directions on the template.



Figure 12

- Locate and loosely install the Driver and Passenger Side Extension Mounting Bracket (Items 9 & 10) using the provided M10 hardware (Item 20) as shown in **Figure 14**.

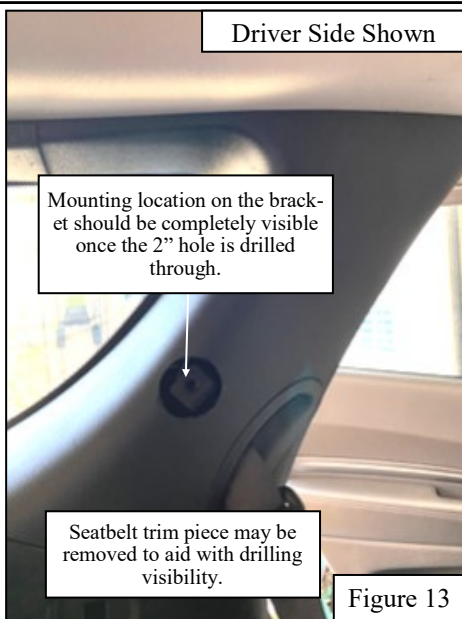

Figure 13



Figure 14



Westin Automotive Products, Inc.  
320 W. Covina Blvd  
San Dimas, Ca. 91773

Thank you for choosing Westin products  
for additional installation assistance please call  
Customer Service (800) 793-7846

www.westinautomotive.com

DATE: 10/06/2023

9. Follow the seatbelt down to its floor mounting location and remove the OEM bolt. See **Figure 15** for reference.
10. Locate and install the Driver and Passenger Floor Straps (Items 7 & 8) loosely using the OEM bolt with room for adjustment as shown in **Figure 16**.

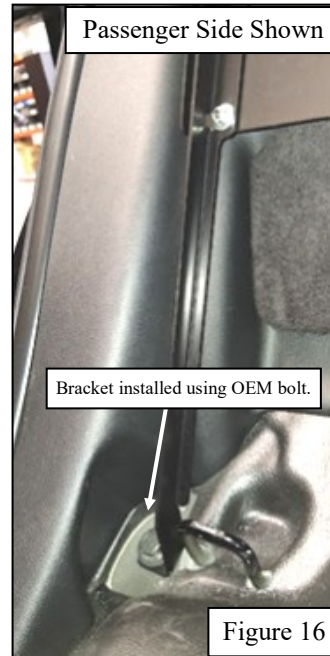
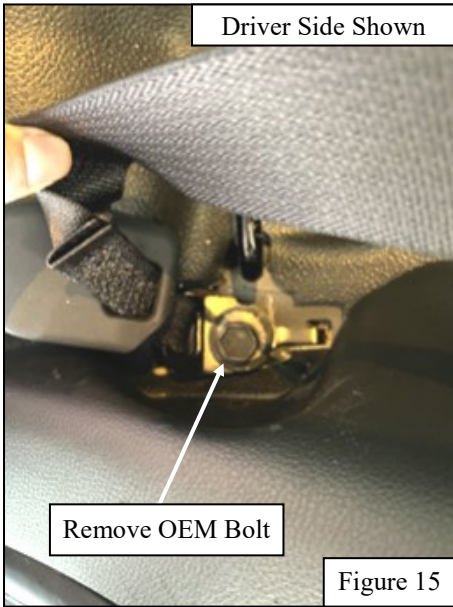

11. Locate and loosely align the Cross Frame (Item 12) to the Driver and Passenger Side Extension Mounting Brackets (Items 9 & 10) as shown in **Figure 17 & 18**.
12. With the Driver and Passenger Floor Straps installed and the Cross Member mounted, locate and loosely install the Center Filer Panel (Item 2) to the floor straps loosely with room for adjustment using the provided M6 hardware (Items 13 & 14) and M8 hardware (Items 15, 18, & 19). See **Figure 19, 20, & 21** for reference.
13. While installing the Center Filer Panel, also install the Belt Support Bracket (Item 11) loosely with room for adjustment with the provided M8 hardware (Items 15, 18, & 19). See **Figure 21 & 22** for reference.



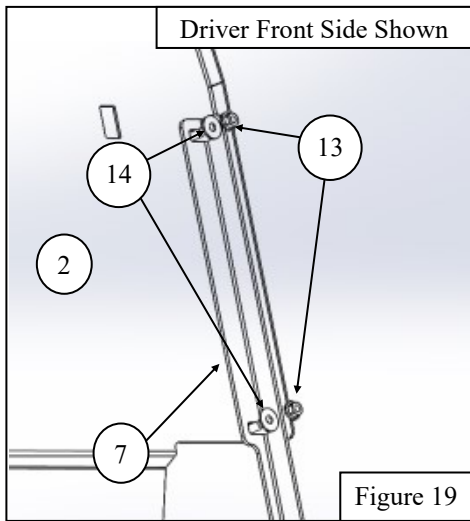

Figure 19

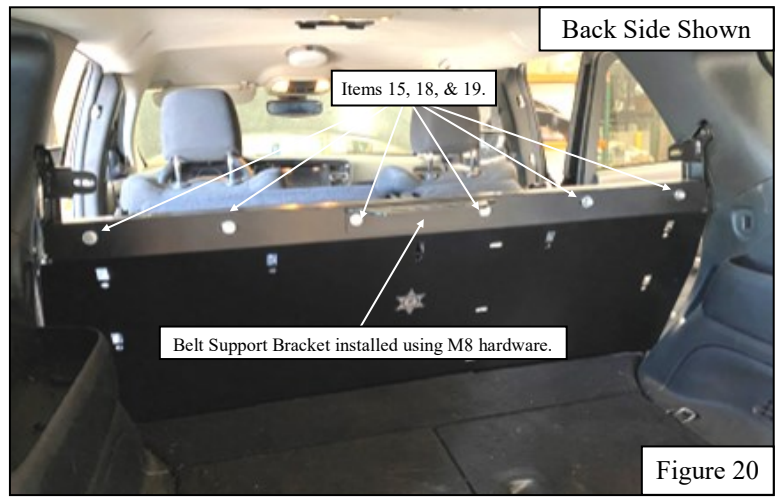

Figure 20

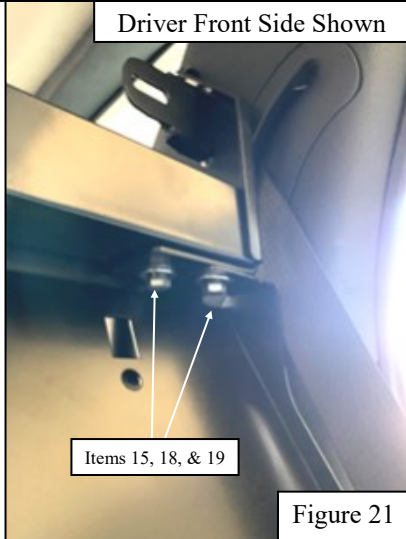

Figure 21

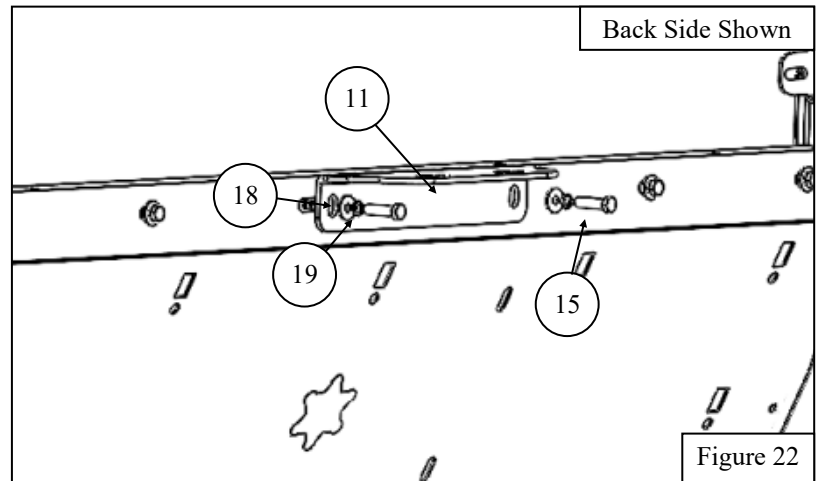

Figure 22

14. If you are installing the optional Prisoner Seat (35-14075), do so at this time. The prisoner seat will mount in between the Cross Frame and Upper Screen. See **Figure 28** for reference.
15. Get frames (**Item 1**) and put them together as shows on figure 23, using M6 hardware 13, 14 and 35.
16. Install the Polywindow (**Item 26**) (**Figure 24**) By installing the Support Bar (Item 34) at the top using M6 Hardware 13, 14 and 24. Then use M6 hardware 13, 14 and 35 all other locations. Do not install hardware at the circled locations at **Figure 24** for now.

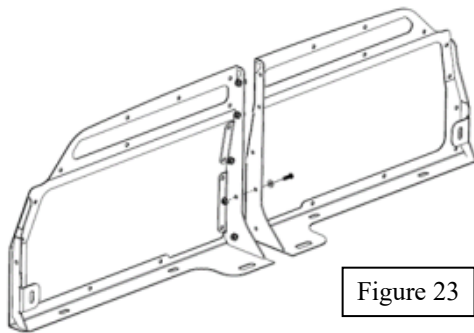

Figure 23

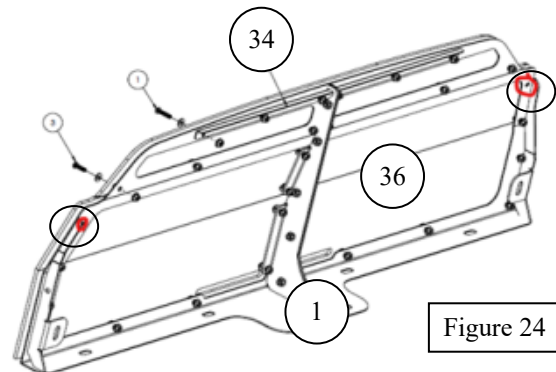
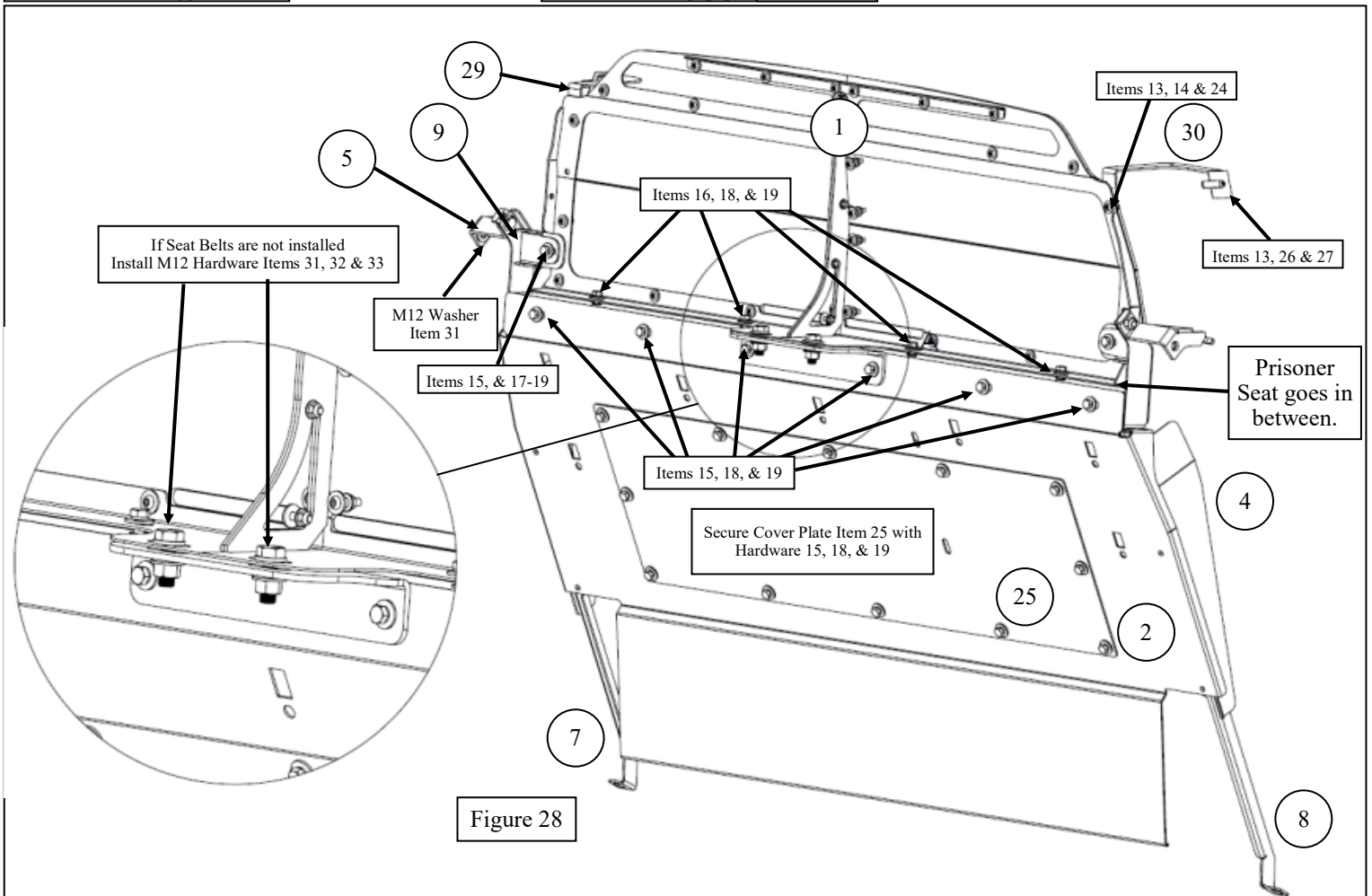
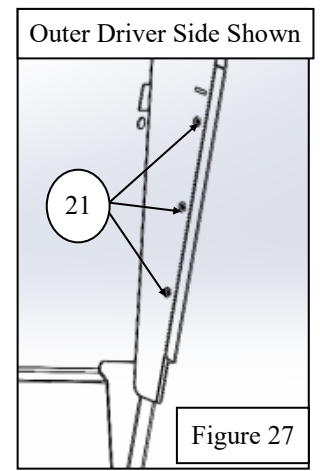
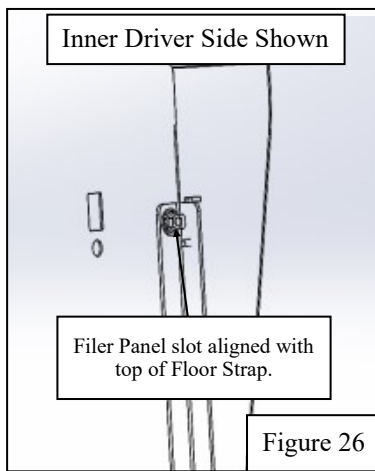
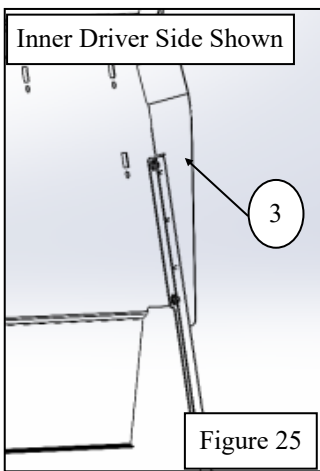

Figure 24

17. Now loosely install the frames and the polywindow using the supplied M8 hardware (Items 16 (long bolt), 16 & 18 & 19) and M6 hardware 13, 14, & 24 at the upper straps locations. See **Figure 28** for reference.
16. Locate and install the Driver and Passenger Side Filer Panels (Items 3 & 4) using the provided #8 Self Tapping Sheet Metal Screws (Item 21). *Note: Make sure to align the Filer Panel slot with the Floor Strap when installing them.* See **Figures 25, 26, & 27** for reference.
17. Install Cover Plate (25) Using M8 hardware **15, 18, & 19**.



17. Adjust and align as needed. Torque hardware as specified: M6 to 8-11 ft. lbs., M8 to 15-18 ft. lbs., M10 to 35-38 ft. lbs.

INSTALLATION COMPLETE



#### CARE INSTRUCTIONS

- REGULAR WAXING IS RECOMMENDED. DO NOT USE ANY TYPE OF POLISH OR WAX THAT MAY CONTAIN ABRASIVES.
- STAINLESS STEEL PRODUCTS CAN BE CLEANED WITH MILD SOAP AND WATER. STAINLESS STEEL POLISH SHOULD BE USED TO POLISH SMALL SCRATCHES.
- GLOSS BLACK FINISHES SHOULD BE CLEANED WITH MILD SOAP AND WATER.

**WESTIN**

Westin Automotive Products, Inc.  
320 W. Covina Blvd  
San Dimas, Ca. 91773

Thank you for choosing Westin products  
for additional installation assistance please call  
Customer Service (800) 793-7846  
[www.westinautomotive.com](http://www.westinautomotive.com)





## WARNING



Failure to follow these instructions could lead to death, personal injury, and / or property damage.

Failure to follow these instructions could lead to death, personal injury, and / or property damage.

### FASTENERS:

All Westin supplied fasteners must be utilized and installed in accordance with the installation instructions and apply torque to the specifications as defined. **DOUBLE CHECK ALL FASTENERS BEFORE INITIAL USE, AND PERIODICALLY IN THE FUTURE TO ENSURE PROPER FUNCTION AND SAFETY.**

### DRILLING:

Most Westin products do not require drilling for installation. If drilling is defined as required, use caution when drilling a vehicle. **FAILURE TO REVIEW AN AREA TO BE DRILLED MAY RESULT IN PERSONAL INJURY AND/OR INJURY TO OTHERS AS WELL AS VEHICLE DAMAGE.**

### EYE PROTECTION:

**ALWAYS WEAR SAFETY GLASSES OR GOGGLES DURING THE INSTALLATION PROCESS TO AVOID PERSONAL INJURY.**

### MAXIMUM TOWING/CARRYING CAPACITY: (if applicable)

The Westin Receiver Hitches will have a visible tow rating label affixed directly on the product. User should never exceed the vehicle manufacturers maximum tow and weight rating regardless of the capacity of the hitch. **FAILURE TO FOLLOW THESE GUIDELINES WILL VOID THE WESTIN WARRANTY AND MAY RESULT IN PERSONAL INJURY AND/OR INJURY TO OTHERS AS WELL AS VEHICLE DAMAGE.**

### FOR CALIFORNIA RESIDENTS ONLY-PROP 65 WARNING:

Some products may contain chemicals such as DEHP, which can cause cancer, birth defects or other reproductive harm. For more info go to [www.p65warnings.ca.gov](http://www.p65warnings.ca.gov)



Westin Automotive Products, Inc.  
320 W. Covina Blvd  
San Dimas, Ca. 91773