

# INSTALLATION INSTRUCTIONS

## DEFENDER PARTITION PRISONER SEAT

APPLICATION: 2021 Chevrolet Tahoe PPV

PART NUMBER: 35-14065



CONTENT			
ITEM	QUANTITY	DESCRIPTION	TOOLS NEEDED
1	1	PRISONER SEAT	17MM SOCKET
2	2	RETRACTOR	3/4" SOCKET
3	2	M12 HEX HEAD BOLT	RATCHET
4	2	M12 NYLOCK NUT	TORQUE WRENCH
5	2	1/2" USS FLAT WASHER	
6	2	BUCKLE LOCK	
7	4	#14 x 1.5 SELF TAPPING SCREWS	
8	2	STORAGE BUCKLE LATCH	
9	2	1/4" BUTTON HEAD BOLT	
10	4	1/4" USS FLAT WASHER	
11	2	1/4" NYLOCK NUT	
12	2	CENTER SEAT BELT HOLES—PLASTIC COVERS	
13	12	#6x3/8" ROUNDED SELF TAPPING SCREWS	

**ANTI-SEIZE LUBRICANT MUST BE USED ON ALL STAINLESS STEEL FASTENERS TO PREVENT THREAD DAMAGE AND GALLING**



## PROCEDURE

1. Remove contents from box, verify if all parts listed are present and free from damage. Carefully read and understand all instructions before attempting installation.  
**Failure to identify damage before installation could lead to a rejection of any claim.**

2. Remove the factory rear seats and passenger/driver side kick panels. See Figure 1-3



3. Locate the prisoner seat and with help, align in the area in front of the rear partition already installed. See Figure 4.  
**Note: Refer to the rear partition installation sheet for hardware (torque) instructions.**

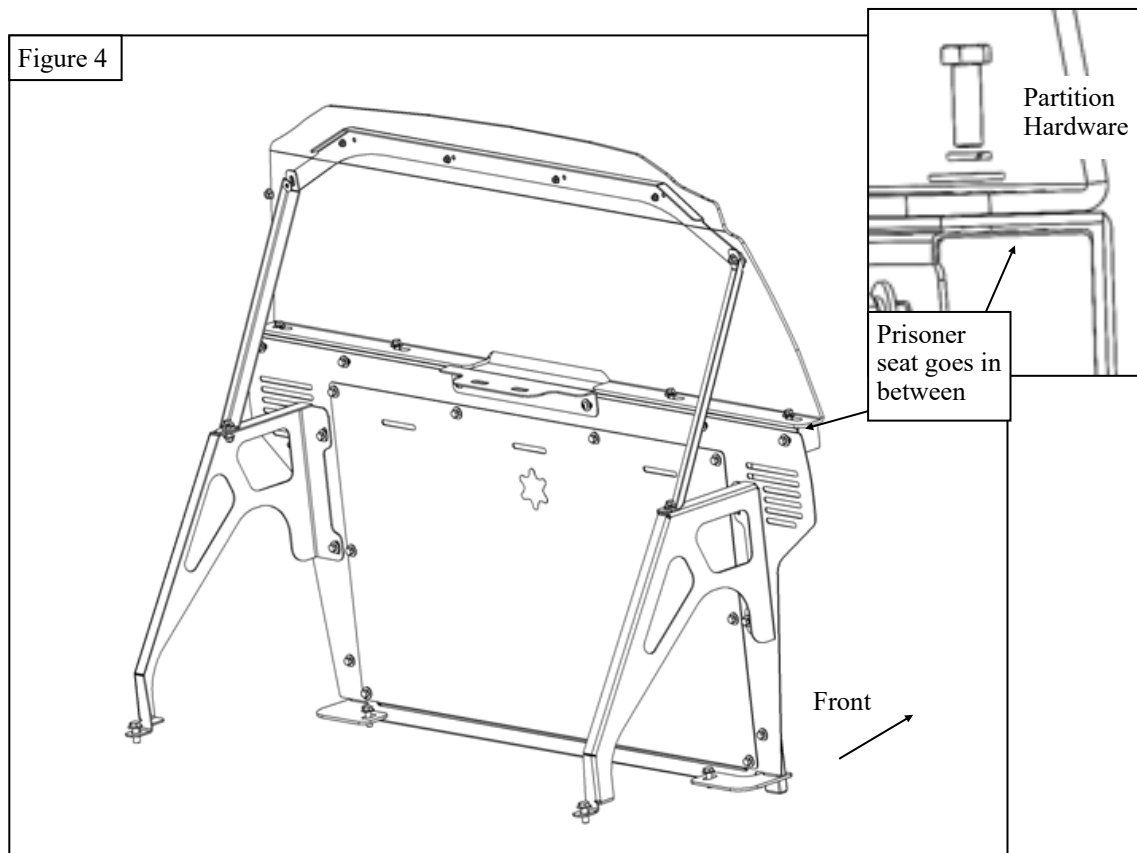

4. Locate the retractors. Remove the plastic cover from the retractors and using supplied M12 hardware, assemble the retractors to the rear partition. Leave hardware slightly loose so that retractors can slightly move for adjustability. See **Figures 5-8**

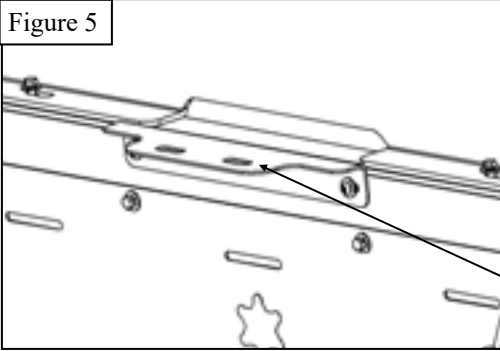

Install retractors here



5. Slide the belt through the seat slots in the middle as shown in **Figure 7-9**.  
 6. Using the factory seat hardware, assemble the belt straps to the floor as shown in **Figures 10 & 11**.  
 7. Using the pre-drilled holes in the front of the seat, install the supplied #4 self tapping screws (7) into the sea and vehicle floor. See **Figure 9**.

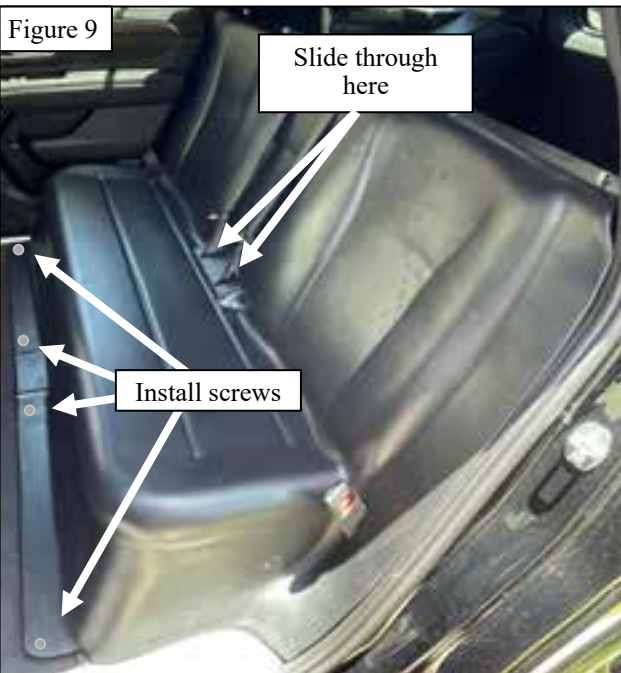

8. Slide the buckle locks through the slot in the seat. Using factory hardware, assemble the buckle locks (6) to the floor. See **Figure 12**.
9. Locate the storage belt buckle latch. Assemble to the front partition as shown in **Figure 13**.
10. Install the seat belt plastic covers with supplied #6 x 3/8" self tapping rounded screws as shown in **Figure 14**.
11. Replace the kick panels previously removed.
12. Tighten all hardware. Torque 1/4" to 8 Ft Lb, 3/8" to 30 Ft Lb, M12 to 65 Ft Lb. 1/2 to 75 Ft Lb. M8 to 27 Ft Lb.

Figure 12

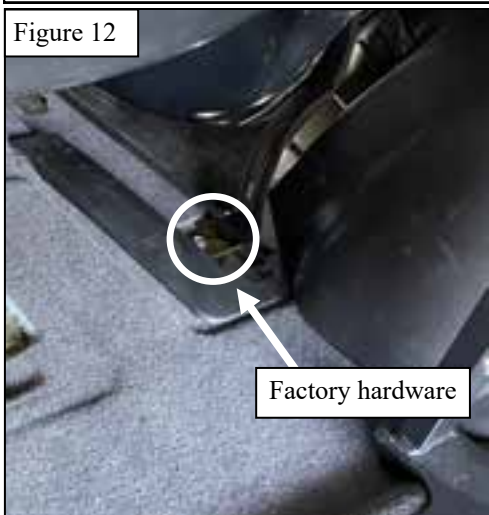

Figure 13



Figure 14

**INSTALLATION COMPLETE**



#### CARE INSTRUCTIONS

- REGULAR WAXING IS RECOMMENDED. DO NOT USE ANY TYPE OF POLISH OR WAX THAT MAY CONTAIN ABRASIVES.
- STAINLESS STEEL PRODUCTS CAN BE CLEANED WITH MILD SOAP AND WATER. STAINLESS STEEL POLISH SHOULD BE USED TO POLISH SMALL SCRATCHES.
- GLOSS BLACK FINISHES SHOULD BE CLEANED WITH MILD SOAP AND WATER.

**WESTIN**

Westin Automotive Products, Inc.  
320 W. Covina Blvd  
San Dimas, Ca. 91773

Thank you for choosing Westin products  
for additional installation assistance please call  
Customer Service (800) 793-7846  
[www.westinautomotive.com](http://www.westinautomotive.com)



## WARNING



Failure to follow these instructions could lead to death, personal injury, and / or property damage.

Failure to follow these instructions could lead to death, personal injury, and / or property damage.

### FASTENERS:

All Westin supplied fasteners must be utilized and installed in accordance with the installation instructions and apply torque to the specifications as defined. **DOUBLE CHECK ALL FASTENERS BEFORE INITIAL USE, AND PERIODICALLY IN THE FUTURE TO ENSURE PROPER FUNCTION AND SAFETY.**

### DRILLING:

Most Westin products do not require drilling for installation. If drilling is defined as required, use caution when drilling a vehicle. **FAILURE TO REVIEW AN AREA TO BE DRILLED MAY RESULT IN PERSONAL INJURY AND/OR INJURY TO OTHERS AS WELL AS VEHICLE DAMAGE.**

### EYE PROTECTION:

**ALWAYS WEAR SAFETY GLASSES OR GOGGLES DURING THE INSTALLATION PROCESS TO AVOID PERSONAL INJURY.**

### MAXIMUM TOWING/CARRYING CAPACITY: (if applicable)

The Westin Receiver Hitches will have a visible tow rating label affixed directly on the product. User should never exceed the vehicle manufacturers maximum tow and weight rating regardless of the capacity of the hitch. **FAILURE TO FOLLOW THESE GUIDELINES WILL VOID THE WESTIN WARRANTY AND MAY RESULT IN PERSONAL INJURY AND/OR INJURY TO OTHERS AS WELL AS VEHICLE DAMAGE.**

### FOR CALIFORNIA RESIDENTS ONLY-PROP 65 WARNING:

Some products may contain chemicals such as DEHP, which can cause cancer, birth defects or other reproductive harm. For more info go to [www.p65warnings.ca.gov](http://www.p65warnings.ca.gov)



Westin Automotive Products, Inc.  
320 W. Covina Blvd  
San Dimas, Ca. 91773