

INSTALLATION INSTRUCTIONS



**DEFENDER PRISONER SEAT
APPLICATION:
Chevrolet Tahoe PPV 2015-2020
PART NUMBER:
35-14025**

CONTENT			
ITEM	QUANTITY	DESCRIPTION	TOOLS NEEDED
1	1	PRISONER SEAT	RATCHET
2	2	SEAT BELT RETRACTOR	TORQUE WRENCH
3	2	OUTER SEAT BELT RECEIVER	18MM SOCKET
4	2	PARTITION SEAT BELT BUCKLE	DRILL MOTOR
5	2	CENTER SEAT BELT HOLES—PLASTIC COVERS	7/32" "L" WRENCH
6	2	OUTER SEAT BELT RECEIVER BRACKET	5MM "L" WRENCH
7	4	M12 HEX HEAD CAP BOLT	1/2 SOCKET
8	4	M12 FLANGE NUT	
9	2	1/4" BUTTON HEAD CAP SCREW	
10	2	1/4" FLAT WASHER	
11	2	1/4" NYLON LOCK NUT	
12	8	#14 SHEET METAL SCREWS	
13	12	#6 X 3/8" SHEET METAL ROUND HEAD SCREW	
14	4	M8 BUTTON HEAD BOLT	
15	4	M8 FLAT WASHER	
16	4	M8 LOCK WASHER	
17	1	PLASTIC FLOOR PLATE	

ANTI-SEIZE LUBRICANT MUST BE USED ON ALL STAINLESS STEEL FASTENERS TO PREVENT THREAD DAMAGE AND GALLING

 ITEM 1	 ITEM 2	 ITEM 3  ITEM 4  ITEM 17	 ITEM 5  ITEM 6
----------------------------------------------------------------------------------------------	-----------------------------------------------------------------------------------------------	---------------------------------------------------------------------------------------------------------------------------------------------------------------------------------------------------------------------------------------------------------------------------------------------------------------	--------------------------------------------------------------------------------------------------------------------------------------------------------------------------------------------------------

PROCEDURE

1. Remove contents from box, verify if all parts listed are present and free from damage. Carefully read and understand all instructions before attempting installation.
Failure to identify damage before installation could lead to a rejection of any claim.
2. This prisoner seat must be installed with Westin Defender Rear Partition 35-12025.
3. Remove the rear seats by removing the four front and four rear nuts under the seats. Retain OEM mounting hardware as this will be required later in the installation process.
4. Cut off the Four Front Seat Mounting Studs as they would stick up in front of the seat and present a serious injury hazard.
5. Remove the factory rear seat belts. Remove factory seatbelt buckles. Also, retain factory seatbelt buckles for vehicle re-sale.
6. **From the install sheet for the Westin Defender Rear Partition 35-12025, stop before proceeding to step 10 and proceed to install the prisoner seat with these instructions.**
7. Using previously removed nuts. Install the outer seat belt brackets (6) at the rear outer studs. (Figure 1).

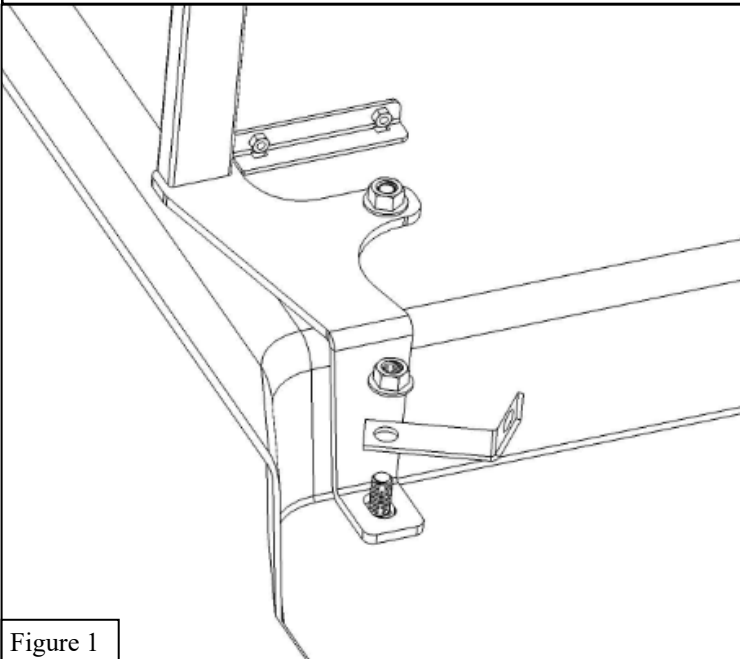

Figure 1



Figure 2

WESTIN

Westin Automotive Products, Inc.
320 W. Covina Blvd
San Dimas, Ca. 91773

8. Position the seat into place (Figures 2 & 3) and with a marker, place a mark on top of the seat aligned at each nut insert location in the frame. Then drill 1/2" holes at each mark. These holes will be used to hold the seat in place. (Figure 3).
9. Place the outer seat belt receiver (3) into the seat outer slots as shown in figure 4. Using the M12 bolt (7) and flange nut (8) install outer seat belt receiver in the seat belt receiver bracket (Figure 5). Torque to 65 ft lb.
10. Proceed to steps 10, 11, and 12 of the rear partition 35-12025 installation instructions. Do not tighten hardware yet.
11. Proceed to step 13 in 35-12025 installation sheet to install the upper part of the prisoner seat. (Figure 3). Use the M8 hardware at each hole. (Figure 3).
12. Get the seat belt retractors (2) and remove the caps on each one, then place the M12" bolts (7) as shown in figure 6.
13. Place the seat belt retractors (2) in top of the bracket as shown in figure 7 and pass the belts through the window guard bottom openings (Figure 8). Align the belt retractors to the openings. Use the M12" (7) and flange nut (8) to lock retractors in place. Tighten and torque to 75 ft lb. Replace the caps on each retractor.
14. Insert the belt brackets through the center slots in the prisoner seat (Figure 9). From underneath, using the previously removed nuts from the seat, attach the belt's brackets to the two center studs (Figure 10). Torque to 65 ft lb.

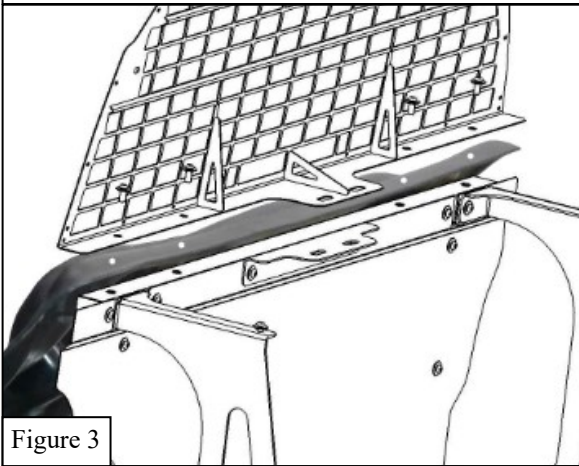

Figure 3



Figure 4

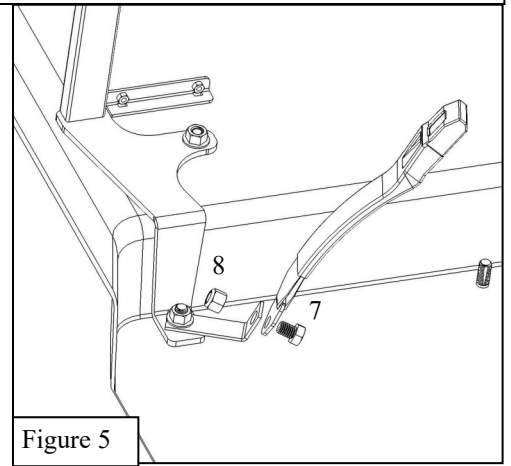

Figure 5



Figure 6



Figure 7



Figure 8



Figure 9

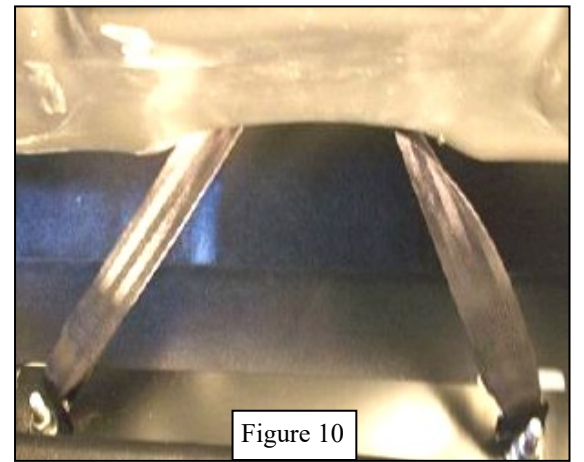

Figure 10

15. Place the plastic floor plate (17) under the seat as shown in figures 11 and 12, and push the seat firmly into place. At the floor area use a 1/8in drill bit to make 8 pilot holes, at equal distances between each hole along and through the prisoner seat (1), floor plate (17), and vehicle floor. Then, install the screws (12) through the holes in the seat and the floor plate and tighten them.
16. Install plastic covers (5) using #6 sheet metal screws (13) (Figure 13).
17. Install the partition seat belt buckles (Item 4) in partition, by using 1/4" hardware items in the Westin 35-10025 partition (Figure 14). Or use the 1/4" (9, 10, 11) hardware to install in other partitions. Drilling will be required in this last option.
18. Tighten all hardware. Torque 1/4" to 8 Ft Lb, 3/8" to 30 Ft Lb, M12 to 65 Ft Lb. 1/2 to 75 Ft Lb. M8 to 27 Ft Lb.



Figure 11

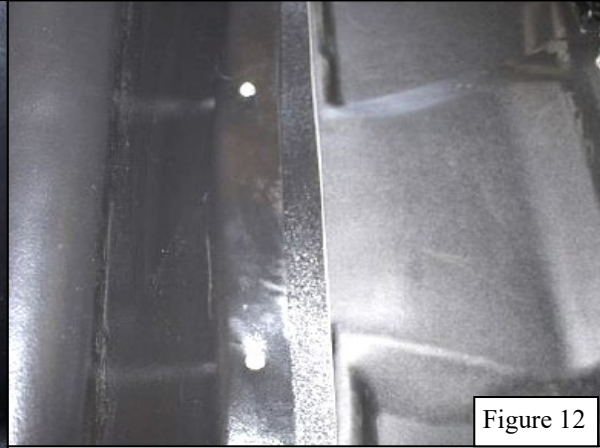

Figure 12



Figure 13



Figure 14

INSTALLATION COMPLETE





WARNING



Failure to follow these instructions could lead to death, personal injury, and / or property damage.

Failure to follow these instructions could lead to death, personal injury, and / or property damage.

FASTENERS:

All Westin supplied fasteners must be utilized and installed in accordance with the installation instructions and apply torque to the specifications as defined. **DOUBLE CHECK ALL FASTENERS BEFORE INITIAL USE, AND PERIODICALLY IN THE FUTURE TO ENSURE PROPER FUNCTION AND SAFETY.**

DRILLING:

Most Westin products do not require drilling for installation. If drilling is defined as required, use caution when drilling a vehicle. **FAILURE TO REVIEW AN AREA TO BE DRILLED MAY RESULT IN PERSONAL INJURY AND/OR INJURY TO OTHERS AS WELL AS VEHICLE DAMAGE.**

EYE PROTECTION:

ALWAYS WEAR SAFETY GLASSES OR GOGGLES DURING THE INSTALLATION PROCESS TO AVOID PERSONAL INJURY.

MAXIMUM TOWING/CARRYING CAPACITY: (if applicable)

The Westin Receiver Hitches will have a visible tow rating label affixed directly on the product. User should never exceed the vehicle manufacturers maximum tow and weight rating regardless of the capacity of the hitch. **FAILURE TO FOLLOW THESE GUIDELINES WILL VOID THE WESTIN WARRANTY AND MAY RESULT IN PERSONAL INJURY AND/OR INJURY TO OTHERS AS WELL AS VEHICLE DAMAGE.**

FOR CALIFORNIA RESIDENTS ONLY-PROP 65 WARNING:

Some products may contain chemicals such as DEHP, which can cause cancer, birth defects or other reproductive harm. For more info go to www.p65warnings.ca.gov



Westin Automotive Products, Inc.
320 W. Covina Blvd
San Dimas, Ca. 91773

Thank you for choosing Westin products
for additional installation assistance please call
Customer Service (800) 793-7846
www.westinautomotive.com